



This manual has been prepared for the owners and operators of the ARMEDICA™ AM-Series Hi-Lo Treatment Tables. It contains installation instructions, precautionary instructions and maintenance procedures for the following model numbers:

**AM-100, AM-150, AM-200, AM-250,
AM-300, AM-350, AM-353, AM-400,
AM-450, AM-500, AM-550**



**ISO 13485
FM 50089**

Made in the U.S.A

AM-SERIES HI-LO TREATMENT TABLES

INSTALLATION

1. Remove all packaging material from the tables.
2. There is no assembly required on the ARMEDICA™ Treatment Tables.
3. Plug the power cord into a properly grounded 120 Volt AC outlet and follow the procedure outlined in the Precautionary Instructions.
4. The table is equipped with leveling glides to be used where necessary to achieve maximum stability.
5. The motor is equipped with a thermal cutout that protects it from overheating.

PRECAUTIONARY INSTRUCTIONS

1. Read, understand and practice the precautionary instructions in this manual. Know the limitations and the hazards associated with the ARMEDICA™ Treatment Tables.
2. The motor is double insulated for protection from EMI. This equipment has been tested and found to comply with the limits for medical devices to the IEC 60601-1-2: Third edition 2007-03. These limits are designed to provide reasonable protection against harmful interference in a typical medical installation. This equipment generates, uses and can radiate radio frequency energy and, if not installed and used in accordance with the instructions, may cause harmful interference to other devices in the vicinity. However, there is no guarantee that interference will not occur in a particular installation. If this equipment does cause harmful interference to other devices, which can be determined by turning the equipment off and on, the user is encouraged to try to correct the interference by one or more of the following measures:
 - Reorient or relocate the receiving device.
 - Increase the separation between the equipment.
 - Connect the equipment into an outlet on a circuit different from that to which the other device(s) are connected.
 - Consult the manufacturer or field service technician for assistance.
3. Always disengage the caster system when the table has been placed in the desired location for patient use.
4. Always use both hands when changing the angle of any section of the table.
5. Never change the angle of any section when the patient's weight is on that section.
6. Never place your hands or feet nor the patient's hands or feet near any of the working mechanisms of the table when raising or lowering the table.
7. **Never leave patient unattended.**

OPERATING INSTRUCTIONS

To adjust the height of the ARMEDICA™ Treatment Tables, a low voltage hand switch or foot switch is used to activate the electric motor assembly. The up or down motion is clearly indicated by arrows.

Duty cycle on/off Int. 1 min./ 9 min.

TABLE SECTION ADJUSTMENTS

The sections of the ARMEDICA™ Treatment Tables are raised by lifting them with both hands. The locking mechanism holds them securely at any angle. To lower a section hold it in one hand and release the locking mechanism by turning the knob with the other.

CAUTION: When lowering any of the table sections, make certain that your hands are placed where they cannot come in contact with the board supports.

CAUTION: When adjusting the sections with the patient on the table, be sure that the patient's weight is not on the section you are going to adjust.

To adjust the center section on the AM-300 and AM-500 the spring-loaded lock must be released before the section can be raised.

CAUTION: When the center section is lowered, make sure that the lock is properly engaged. To adjust the foot section on the AM-400 and AM-450, rotate the knob to the unlock position. To adjust the arm rest on the 3 piece head section, use two hands placed on each end and pull out to the side then raise or lower into the up or down position and release.

CAUTION: Make sure the arm rest on the 3 piece head section is locked securely in position before the patient places any weight on it.

POWER ASSISTED CASTER SYSTEM

To activate the casters, the table must be elevated at least 6 inches above the minimum height. Pull to slide the caster lever bar toward the foot end of the table and lock into position. Lower the table to the minimum height. The table is now on casters and can be repositioned. When the table is in the desired location raise it up 6 inches, lift the lever bar and slide in toward the head of the table. This will move the activator support bar forward and disengage the caster system. If the table is not level in its new location, adjust the leveling glides to insure maximum stability.

MAINTENANCE

The ARMEDICA™ Treatment Tables are equipped with a maintenance free electric motor. The moving parts of the table should have a drop of oil placed on them approximately every six months.

Frequently check to make certain that all hardware (nuts, bolts, etc.) are properly adjusted and securely fastened.

In the event it becomes necessary to replace the hand switch, foot switch or the power cord, make certain that the plug is in properly and the locking tabs on the motor snaps in place.

The vinyl cover should be cleaned with mild soap and water and the table frame wiped with a dry cloth to remove dust and lint when necessary.

SYMBOLS AND INDICATORS



Attention: Consult accompanying documents.



Type B Equipment: "An adequate degree of protection against electric shock is provided, particularly regarding leakage currents and reliability of the protective earth connection."



The grounding pin located on the power supply cable is for Functional use only, and is present for EMI/ EMC purposes. The motor is Class II equipment and does not rely on this grounding means for safety.

TROUBLE SHOOTING

MOTOR DOESN'T WORK.

- A. Check to see if motor is plugged into receptacle, and the power cord is properly plugged into the motor.
- B. Make sure receptacle is getting power.
- C. Check hand switch or foot switch to be sure it is plugged in.
- D. Thermal cutout may have activated. Allow the motor to cool.
- E. In the event there is a failure of the motor, the motor must be returned to Armedica Mfg. Corp. The motor must be serviced by the manufacturer.

MOTOR SPECIFICATIONS

Magnetic Corp., Olney, Illinois 62450
Model MAX 65-A200415A1001-000.
Rated Voltage and Frequency 120V 60HZ.
Current 1.8 Amps.
UL CORD SET 140-355
Duty cycle: on/off Int. 1 min. / 9 min.

TABLE LIFTING CAPACITY: 400 LBS. (181 KILOGRAMS)

PARTS LIST								
ITEM NO.	PART NO.	DESCRIPTION	QUANTITY					
			100	200	300	350	400	500
			150	250		353	450	550
1	18107	BASE FRAME	1	1	1	1		1
2	02025	BOLT SHOULDER M 12x50	2	2	2	2	2	2
3	03105	MOTOR MAX65 8000N 120V	1	1	1	1	1	1
4	02015	BOLT SHOULDER 1/2x1/2	10	10	10	10	10	10
5	03015	PLUG 1x2	10	10	10	10	11	10
6	03020	PLUG 1-1/2x2-1/2	6	6	6	6	6	6
7	02010	BOLT SHOULDER 5/16x1-1/2	2	2	2	2	2	2
8	03055	WHEEL 2x7/8	2	2	2	2	2	2
9	02100	NUT NYLOCK 1/4-20	2	4	10	6	8	8
10	02115	NUT NYLOCK M10-1.5	2	2	2	2	2	2
11	18113	LIFTING ARM HEAD END	1	1	1	1	1	1
12	18184	CONTROL ROD 3 PC	1	1	1	1	1	1
13	18111	LIFTING ARM FOOT END	1	1	1	1	1	1
14	03010	PLUG 1x1	6	6	6	6	6	6
15	02020	BOLT SHOULDER 1/2x2	2	2	2	2	2	2
16	18123	CASTER YOKE BRACKET	1	1	1	1	1	1
17	02060	SCREW FLAT HEAD PHIL 1/4-20x1/2	2	2	2	2	2	2
18	13098	BUMPER CASTER YOKE	1	1	1	1	1	1
19	12006	BAR 1/4x3/4x8-5/8 CSTR LK LVR	1	1	1	1	1	1
20	18121	CASTER PIVOT BRACKET	1	1	1	1	1	1
21	02049	SCREW HEX HEAD 3/8x3	1	1	1	1	1	1
22	02090	NUT NYLOCK 1/2-13	1	1	1	1	2	1
23	02145	WASHER 1/2	1	1	2	1	1	2
24	03050	CASTER SWIVEL	1	1	1	1	1	1
25	03060	GLIDE LEVELER BASE	2	2	2	2	2	2
26	02110	NUT NYLOCK 3/8-16	3	3	3	3	3	3
27	02130	NUT HEX FINISH 5/16-18	1	1	1	1	1	1
28	18136	TOP FRAME 100	1					
29	14827	UPHOLSTERED BOARD 100 TOP 27"	1					
30	02070	SCREW HEX WASHER HEAD #14x1-3/4	6					
31	18138	TOP FRAME 200		1				
32	02075	SCREW HEX WASHER HEAD #14x2-1/2		6				
33	13016	THREADED ROD 1/2x21 HEAD SECTION		1	1	1	1	1
34	03070	KNOB WING 1/2X13 ID		2	6	4	4	4
35	13095	PLASTIC SPACER		2	2	2	2	2
36	03030	TORSION SPRING LESS BEND RIGHT		1	1	1	1	1
37	18446	ROD 1/2x11-11/16 HEAD SECTION SUPPORT		2	2	2	2	2
38	02035	SCREW BUTTON HEAD 5/16x1-1/2		2	6	4	4	6
39	02105	NUT NYLOCK 5/16-18	1	3	7	5	7	7
40	02065	SCREW HEX WASHER HEAD #14x1		4	14	14	4	14
41	18115	HEAD SECTION FRAME		1	1	1		
42	03040	TORSION SPRING LESS BEND LEFT		1	1	1	1	1
43	02005	BOLT SHOULDER 5/16x3/4		2	6	4	4	6
44	02135	NUT HEX THIN PATTERN 1/2-13		2	6	4	4	6
45	18127	LOCK SUPPORT BRACKET		2	6	4	4	6
46	14812	UPHOLSTERED HEAD BOARD 27"		1	1	1	1	
47	14826	UPHOLSTERED BODY BOARD 200 27"		1				
48	14813	UPHOLSTERED CENTER BOARD 27"			1	1		1
49	14814	UPHOLSTERED FOOT BOARD 27"			1	1		1
50	03065	GLIDE 1/4-20x1			4	2		4
51	13026	THREADED ROD 1/2x23 FOOT SECTION			2	1	1	1
52	03035	TORSION SPRING LEFT			2	1	1	2
53	03025	TORSION SPRING RIGHT			2	1	1	2
54	18444	ROD 1/2x24-3/16 FOOT SECTION SUPPORT			2	2		2
55	18140	TOP FRAME 300			1			
56	18119	FOOT SECTION FRAME			1	1		
57	18117	CENTER SECTION FRAME 300			1			
58	18144	CENTER SECTION LOCK BAR 300			1			
59	03095	SPRING M30 EXTENSION			1			
60	13021	THREADED ROD 1/2x23 CENTER SECTION			1			
61	18448	ROD 1/2x8-11/16 CENTER SECTION SUPPORT			2			
62	14801	UPHOLSTERED ARMREST LEFT		1			1	1

PARTS LIST								
ITEM NO.	PART NO.	DESCRIPTION	QUANTITY					
			100	200	300	350	400	500
			150	250		353	450	550
63	14800	UPHOLSTERED ARMREST RIGHT		1			1	1
64	14802	UPHOLSTERED HEAD BOARD 500		1			1	1
65	18150	HEAD SECTION FRAME 500		1			1	1
66	02044	SCREW HEX HEAD 1/4-20x1-1/4		4			4	4
67	02143	FENDER WASHER 1/4"IDx1"OD		2			2	2
68	02042	BUTTON HEAD SCREW 1/4-20x1/2		2			2	2
69	02175	SPRING PIN 1/4x1-1/2		2			2	2
70	03096	SPRING M52		2			2	2
71	03005	PLUG 1/2x1		4			4	4
72	18152	ARMREST BRACKET LEFT		1			1	1
73	18154	ARMREST BRACKET RIGHT		1			1	1
74	03073	KNOB PULL 1/2-13 ID		2			2	2
75	18291	TOP FRAME 350				1		
76	03106	FOOTSWITCH MAX65 8000N	1	1	1	1	1	1
77	03113	HAND SWITCH MAX65 (OPTIONAL)	1	1	1	1	1	1
78	03107	POWER CORD	1	1	1	1	1	1
79	12511	STRAP HOOK 400					2	
80	14501	UPHOLSTERED THORACIC BOARD AM-400					1	
81	14502	UPHOLSTERED LUMBAR BOARD AM-400					1	
82	14503	UPHOLSTERED FOOT BOARD AM-400					1	
83	18452	ROD 1/2x18 FOOT SECTION SUPPORT					1	
84	13504	THREADED ROD 17-1/4 FT SECTION LOCK-400					1	
85	18501	ROLLER FRAME AM-400					1	
86	03066	BEARING KILLIAN F300					4	
87	18516	HANDLE LOCK RELEASE400 RIGHT					1	
88	02095	NUT NYLOCK 1/2-13 THIN PATTERN			1		2	1
89	02165	WASHER NYLON 1/2 ID	10	10	11	10	12	11
90	02045	SCREW HEX HEAD 1/4-20x1					8	
91	18512	TOP FRAME AM-400					1	
92	12519	GEAR RACK PLUNGER LOCK					1	
93	12527	GEAR LOCK PULLER					1	
94	13526	BUSH CAM .515 ID LOCK MECH					1	
95	18522	HANDLE LOCK RELEASE 400LEFT					1	
96	18506	FOOT SECTION FRAME AM- 400					1	
97	06035	DECAL LOCK/UNLOCK RIGHT					1	
98	06036	DECAL UNLOCK/LOCK LEFT					1	
99	18520	BASE FRAME AM-400					1	
100	18514	FRAME MACHINE STAND AM-400					2	
101	03008	PLUG 1x1-1/2					2	
102	12751	PLATE 1/8x6-1/2					1	
103	14508	ADAPTER BOARD					1	
104	03125	KNOB "T" SPRNG LOAD PULL PIN 1/4DIA					1	
105	02162	SPACER PLASTIC .33 IDx.565 ODx.56				2	2	2
106	02160	WASHER NYLON 5/16 ID		4	12	8	8	8
107	02166	SPACER NYLON 1-1/4ODx17/64IDx3/4		6				
108	02150	WASHER 5/16	4	12	6	6	6	4
109	12525	BAR GEAR RACK 1/2x1/2x8-1/2					1	
110	02170	PIN SPRING 3/16x1		2	6	4	4	4
111	03019	CAP 3/8 BLACK					2	
112	02030	BOLT CARRIAGE 1/4-20x2					1	
113	02120	NUT HX FIN 1/4-20			2	2	2	2
114	02188	BOLT SHLDR 5/16X1-1/4				2		
115	03013	CAP .312x4 BLK PLASTIC TUBE					2	
116	02054	SCREW HX HD CAP 1/4-20x1-3/4					4	
117	02073	SCREW FLT HD PHIL 1/4-20x1-1/2					2	
118	02039	SCREW HX HD CAP 5/16-18x1-1/4					1	
119	02089	NUT NYLOCK 10-32					1	
120	02097	NUT HX FIN 10-32					1	
121	02095	NUT NYLOCK JAM 1/2-13					1	
122	02168	SPACER NYLON .980 ODx.352 IDx1/2					1	
123	02101	SCREW PAN HD PHIL 10-32x1					1	
124	13521	ROD 1/2x23 THD'D 400 CAM LOCK PLTD					1	

TABLE BASE
AM SERIES

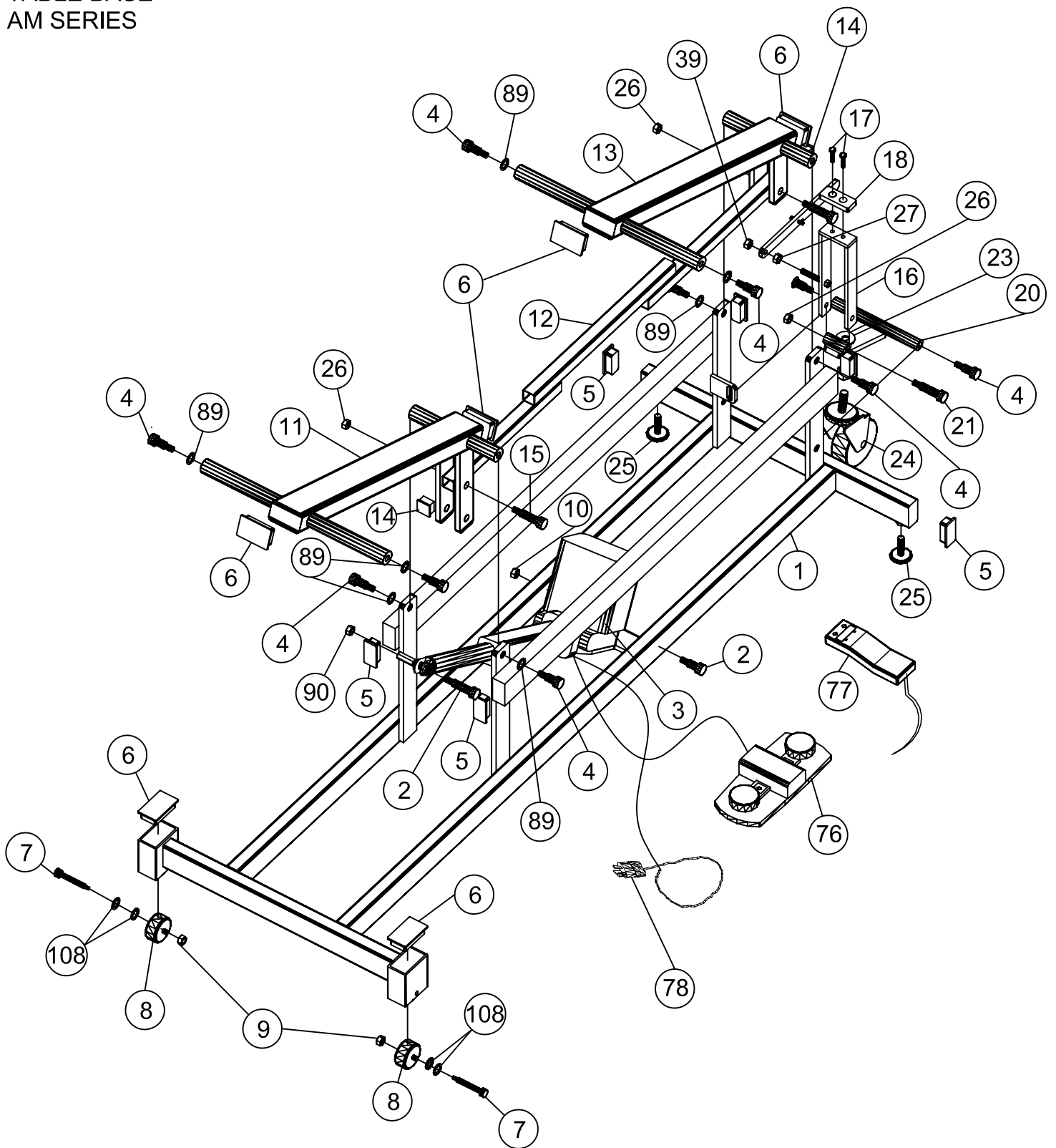

**TOP FRAME
AM-100**

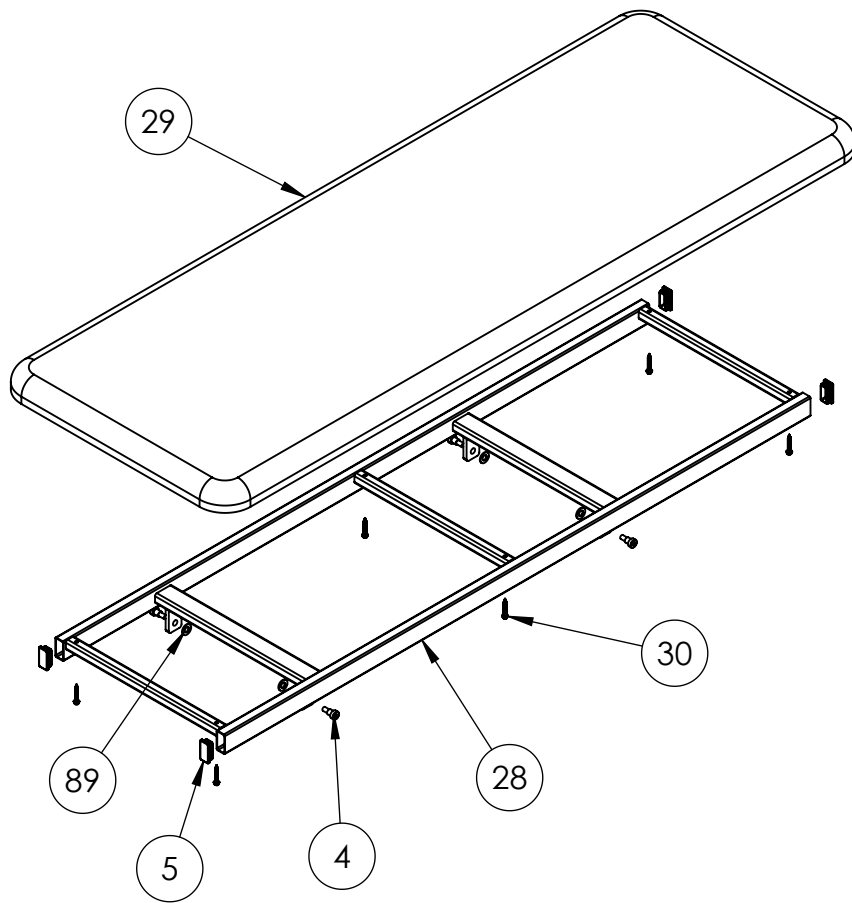

**TOP FRAME
AM-200**

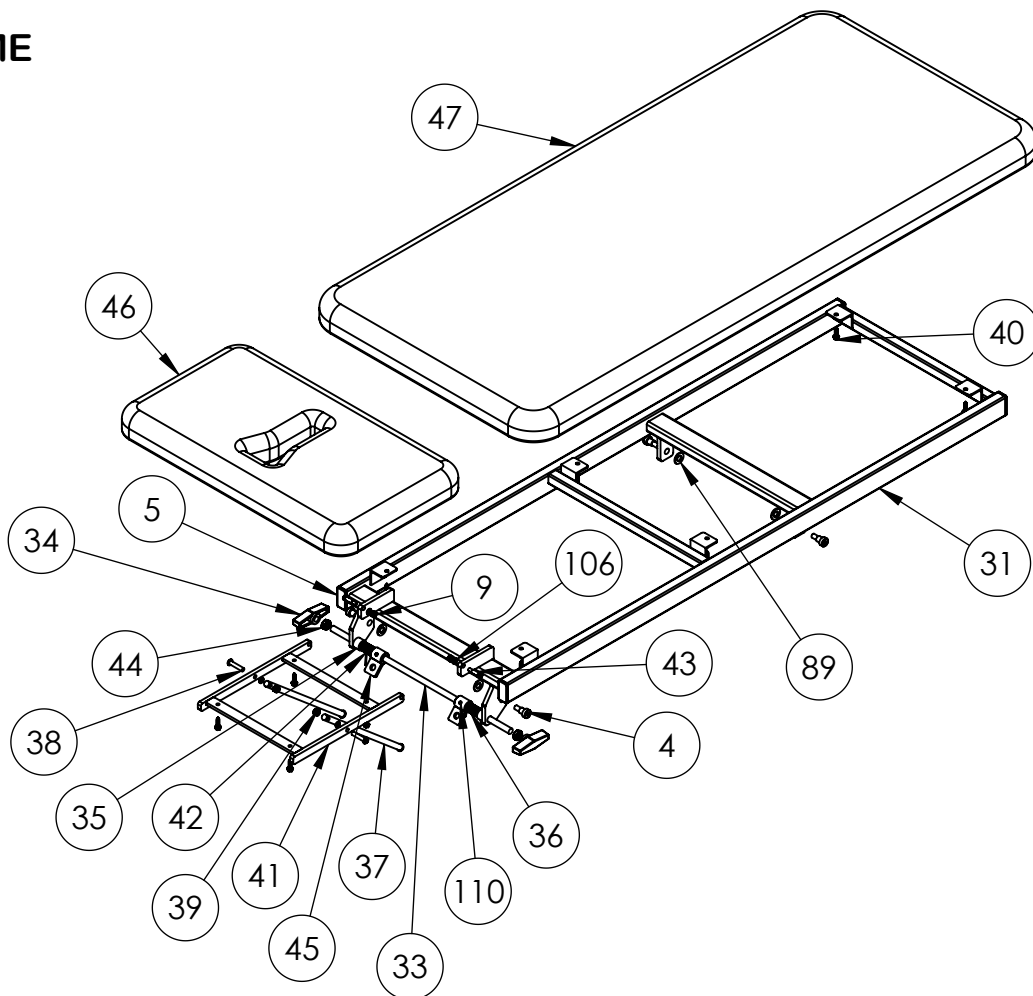

**TOP FRAME
AM-300**

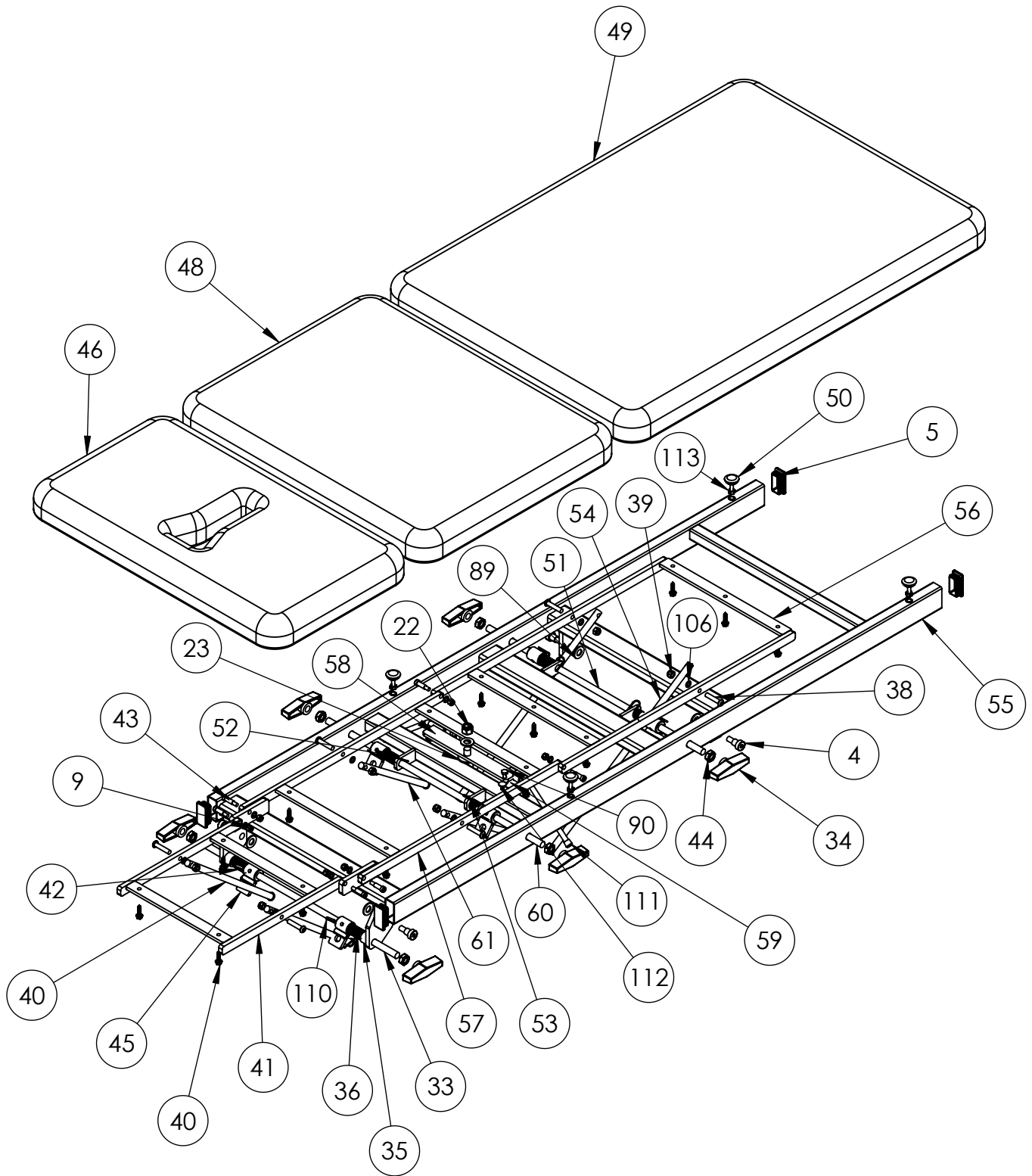

**TOP FRAME
AM-350**

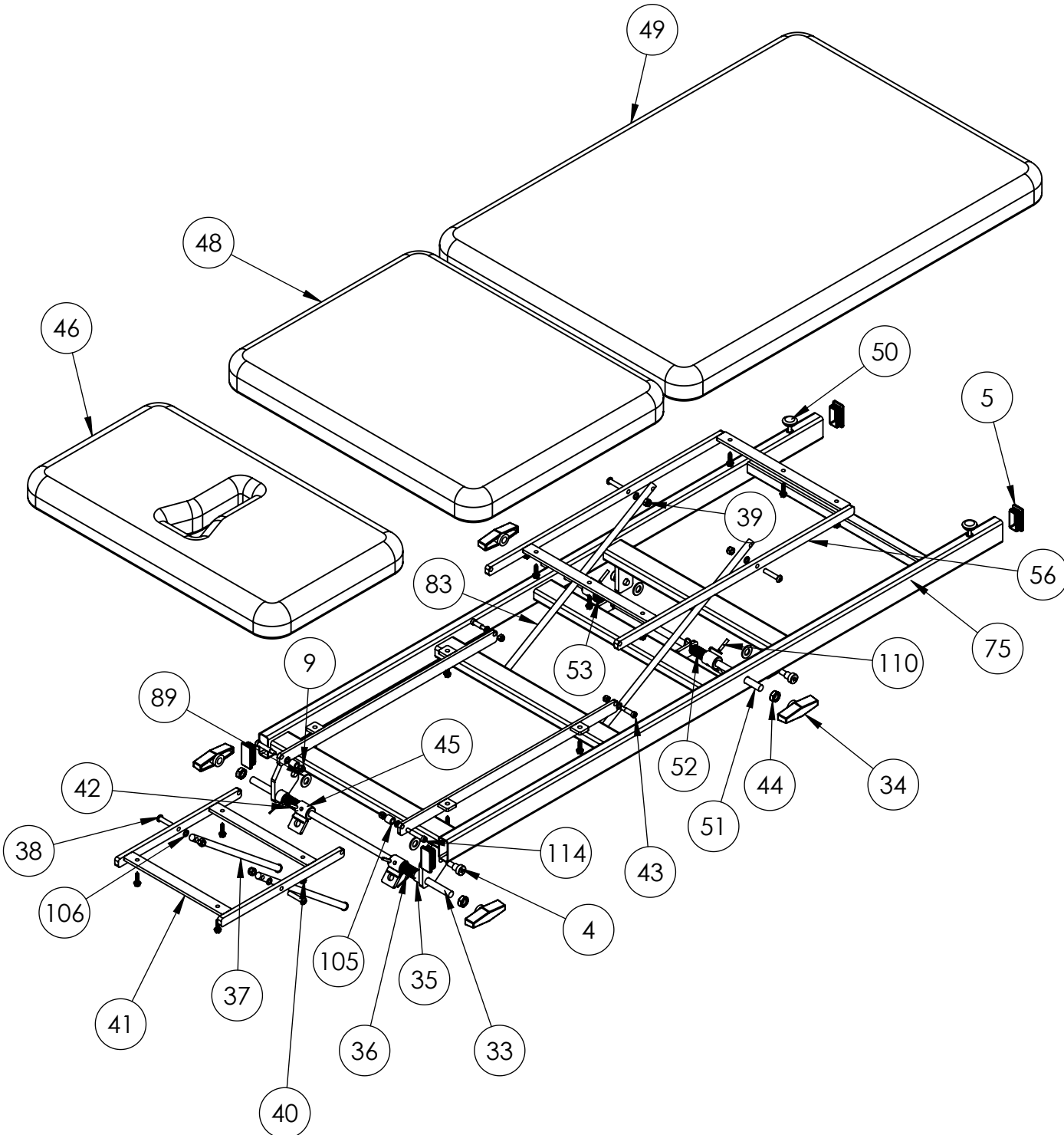

SWIVEL STAND
AM-400, 450

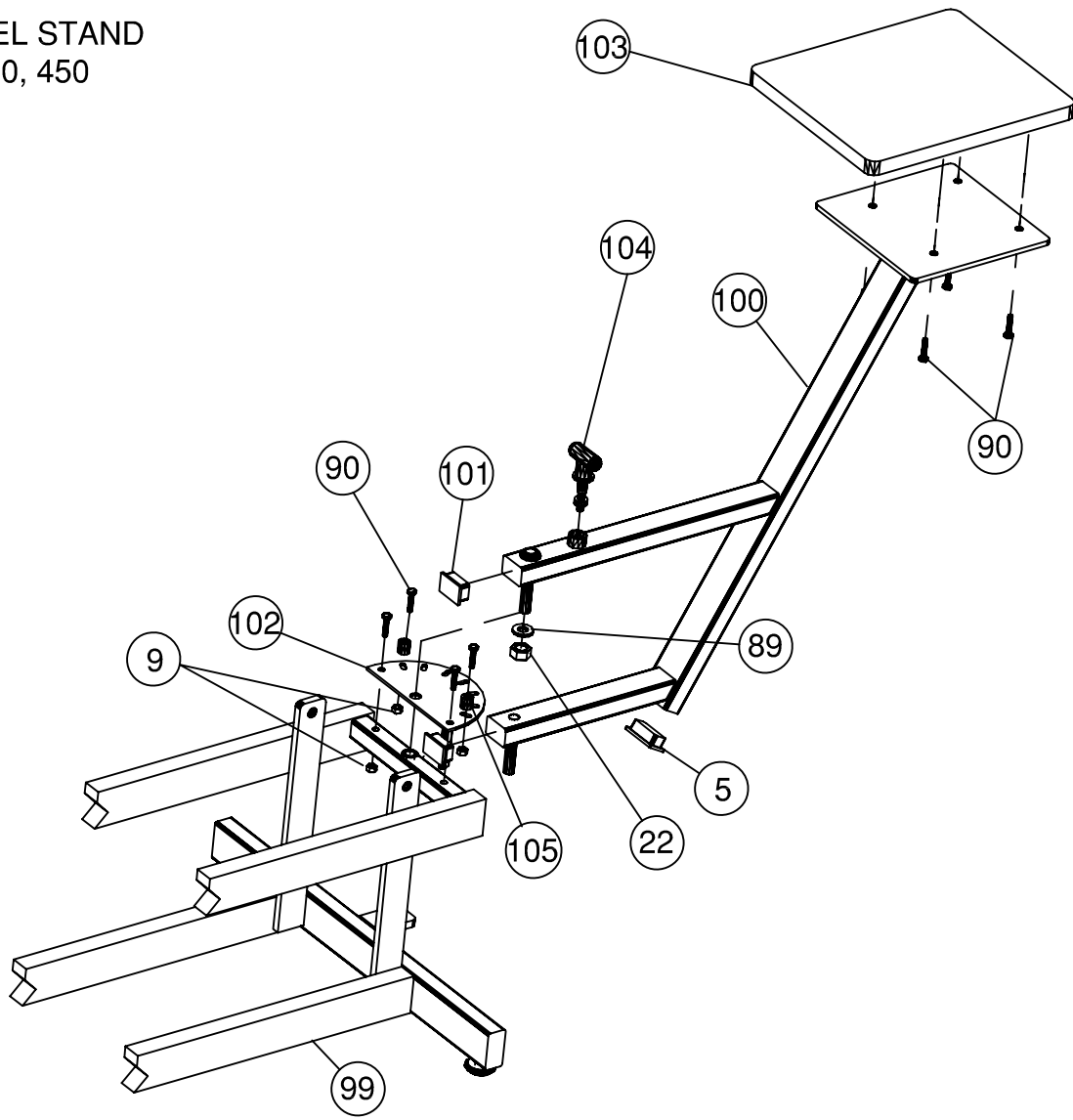

HEAD PIECE
AM-250, 450, 500, 550

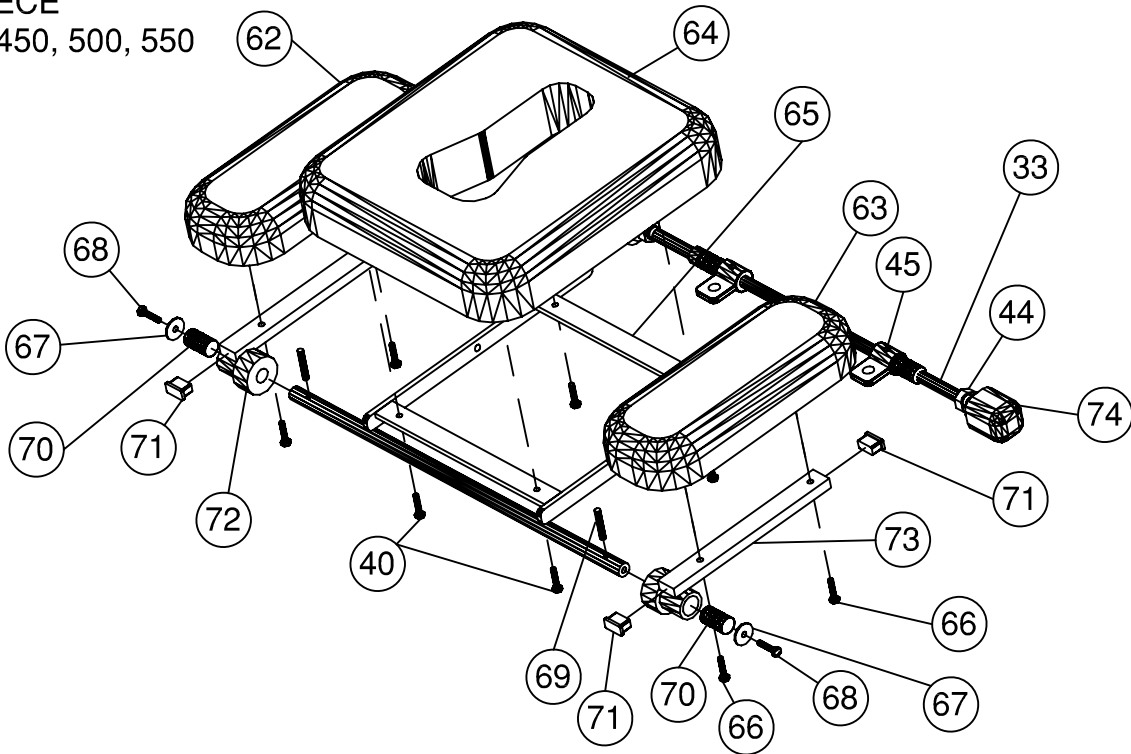

**ARMEDICA™ MANUFACTURING CORP.
LIMITED WARRANTY**

ARMEDICA™ Manufacturing Corp. warrants that the AM Series treatment tables are free from defects in material and workmanship. This warranty shall remain in effect for 18 months from the date of original consumer purchase of the product. If the product fails to function during the warranty period due to a defect in material or workmanship, ARMEDICA™ Manufacturing Corp. or the selling Dealer will repair or replace the table without charge within a 30 day period from the date on which the table is returned to ARMEDICA™ Manufacturing Corp. or the selling Dealer.

THIS WARRANTY DOES NOT COVER

1. Replacement parts or labor furnished by anyone other than ARMEDICA™, Selling Dealer or approved ARMEDICA™ Service Agent.
2. Any failure of the table during the warranty period if the failure is not caused by a defect in material or workmanship or if the failure is caused by unreasonable use, including the failure to provide reasonable and necessary maintenance.

**ARMEDICA™ MANUFACTURING CORP. IS NOT LIABLE FOR INCIDENTAL
OR CONSEQUENTIAL DAMAGE TO PROPERTY OR BUSINESS.**

To obtain service under this warranty, please do the following:

1. A written claim should be sent to ARMEDICA™ Manufacturing Corp., P.O. Box 880, Greenwood, AR. 72936-0880 or the selling Dealer.
2. The table must be returned to ARMEDICA™ Manufacturing Corp. or the selling Dealer.
3. This warranty gives you specific legal rights and you may have other rights, which vary from state to state

ARMEDICA™ does not authorize any person or dealer to create for it any other obligations or liabilities in connection with the sale of the tables. Any representation or agreement not contained in this warranty shall be void.



ARMEDICA MANUFACTURING CORP.
Greenwood, AR 72936-0880

Model No. Serial No.

DANGER: Risk of explosion if used in the presence of flammable anesthetics. Duty cycle: On/Off Int. 1 min./9 min.
Lifting capacity 400 lb. (181 kg.) 120 Volts 60 Hz 1.8 Amps

 **CLASSIFIED**
UL **US**
3JF7
E233290

Medical Electrical Equipment
With respect to electrical shock,
Fire and mechanical hazards only
In accordance with 2601-1

PN 06008A