

*Johnny G*  
**KRANK**cycle<sup>®</sup>  
by **MATRIX**

# TABLE OF CONTENTS

|     |   | PAGES |
|-----|---|-------|
|     | <b>CHAPTER 1: IMPORTANT SAFETY INSTRUCTIONS</b>                         |       |
| 1.1 | Read and Save These Instructions.....                                   | 02    |
| 1.2 | Proper Usage .....  | 02    |
| 1.3 | Setting up the KRANKcycle™.....   | 02    |
|     | <b>CHAPTER 2: KRANKcycle™ SPECIFICATIONS, PARTS AND ASSEMBLY GUIDES</b> |       |
| 2.1 | Specifications .....  | 03    |
| 2.2 | Required Parts, Fasteners and Tools .....                               | 04    |
| 2.3 | Assembly Steps .....  | 05    |
|     | <b>CHAPTER 3: GETTING TO KNOW THE KRANKcycle™</b>                       |       |
| 3.1 | Diagram .....   | 09    |
|     | <b>CHAPTER 4: USING THE KRANKcycle™</b>                                 |       |
| 4.1 | Proper Setup .....  | 10    |
| 4.2 | How to Operate .....  | 10    |
| 4.3 | How to Move .....   | 11    |
|     | <b>CHAPTER 5: PLACEMENT OF SERIAL NUMBER ON KRANKcycle™</b>             |       |
| 5.1 | Serial Number Location.....   | 12    |
|     | <b>CHAPTER 6 PREVENTATIVE MAINTENANCE</b>                               |       |
| 6.1 | Daily Maintenance .....   | 12    |
| 6.2 | Weekly Maintenance .....  | 12    |
| 6.3 | Monthly Maintenance .....   | 12    |
| 6.4 | Bi-yearly (6 Month) Maintenance .....                                   | 13    |
| 6.5 | Troubleshooting Guide .....   | 13    |

## 1.1 READ AND SAVE THESE INSTRUCTIONS

---

It is the sole responsibility of the purchaser of Matrix Fitness Systems products to instruct all individuals, whether they are the end user or supervising personnel, on proper usage of the equipment.

It is recommended that all users of Matrix Fitness Systems exercise equipment be informed of the following information prior to its use.

## 1.2 PROPER USAGE

---

- Do not use the equipment in any way other than designed or intended by the manufacturer. It is imperative that all Matrix Fitness Systems equipment is used properly to avoid injury.
- Keep the KRANKcycle™ indoors, away from moisture and dust. Do not place the KRANKcycle™ in a garage or covered patio or near water.
- Place the KRANKcycle™ on a level horizontal surface. To protect the floor or carpet from damage, place a mat beneath the KRANKcycle™. Make sure that there is 20 inches (0.5m) minimum distance to other equipment around the KRANKcycle™ to mount, dismount, and operate it.
- Children under the age of 18 should only be allowed to use the KRANKcycle™ with parental approval and if guided by a trained instructor. Unaccompanied minors should not be allowed to use the KRANKcycle.
- The KRANKcycle™ should not be used by persons weighing more than 350 lbs / 159 kg.
- Always wear appropriate athletic clothing and shoes while operating the KRANKcycle™. Do not wear loose clothing that could become caught on the KRANKcycle™ or shoes with loose laces.
- Before using the KRANKcycle™, make sure that you are familiar with the setup/operation of the KRANKcycle™ (see page 10).
- Make sure seat hooks are fully engaged around protruding center pin.
- Both the rotation adjustment and pivoting height adjustment should be fully engaged and locked into position before using the KRANKcycle™.
- The KRANKcycle™ has independent crank arms which will stop moving once the user stops; however, the flywheel will continue to move.
- Always regulate the flywheel resistance so that your upper body movements are controlled.
- Keep your grip light while kranking and keep your elbows in a neutral position.
- If you feel pain or dizziness while exercising, STOP immediately, rest, cool down and consult a physician.
- If replacement parts are needed, use only manufacturer supplied parts.
- Do not operate this cycle with 2 people, equipment is designed for individual use.
- Stay clear of moving parts and place both hands on the crank handles while exercising
- Stop your workout in the event a person is within reach of moving parts

### **!WARNING!**

To reduce the risk of serious injury, read the following important precautions and information before operating the KRANKcycle™.

### **!WARNING!**

Before beginning any exercise program, consult your physician. This is especially important for persons over the age of 35 or persons with pre-existing health problems. Carefully read all instructions before use. Be aware that incorrect or extensive training may result in serious health injuries. The manufacturer assumes no responsibility for personal injury or property damage sustained by or through the use of this product.

### **!WARNING!**

Regularly inspect and properly tighten all parts of the KRANKcycle™ as recommended in this manual. Please replace defective and heavy wear parts (like the brake pad) immediately and do not use the cycle until repair is performed. Only use original parts from the manufacturer.

## 1.3 SETTING UP THE KRANKcycle™

---

Assembly Instructions have been provided with your cycle. For your safety, please read and follow each of the steps in the assembly guide.

## CHAPTER 2: KRANKcycle™ SPECIFICATIONS, PARTS AND ASSEMBLY STEPS

### 2.1 JOHNNY G KRANKcycle™ BY MATRIX SPECIFICATIONS

The Johnny G KRANKcycle™ by Matrix is designed according to EN957-5 standards as a Class S subcategory C product for professional and / or commercial use. Such training equipment is intended for use in training areas of commercial facilities such as Fitness Clubs or Sport Associations, where access and control is regulated by the person who has legal responsibility. The Johnny G KRANKcycle™ is not suited for therapeutic use.

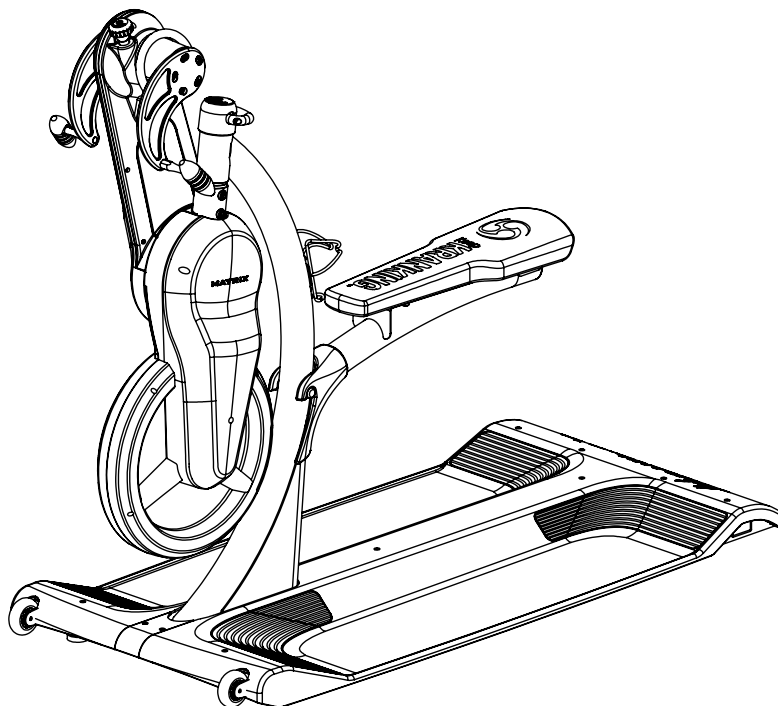











#### Specifications

|                       |   |
|-----------------------|---|
| Foot print:           | 56.5" L x 26.8" W x 41.5" H / 1.44m L x 0.68m W x 1.06m H |
| Weight of bike:       | 142.4 lbs / 64.6 kg                                       |
| Saddle height:        | 24.3" / 0.62m   |
| Max crank arm height: | 53.5" / 1.36m   |
| Max user weight:      | 350 lbs / 159 kg  |

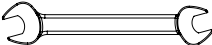
The KRANKcycle™ is designed to accommodate most users from 150 to 205 cm / 59 to 81 inch Body height.

## 2.2 REQUIRED PARTS, FASTENERS & TOOLS (NOT INCLUDED)

|    | Part Name:                | Outline:  | Dimensions:      | Quantity: | Bag Color: |
|----|---------------------------|---|------------------|-----------|------------|
| 1  | Flat Washer               |    | M10              | 4         | Black      |
| 2  | Socket Head Cap Screw     |    | M10 x 25mm       | 4         | Black      |
| 3  | Phillips Head Screw       |    | M4 x 8mm         | 10        | Red        |
| 4  | Socket Head Cap Screw     |    | M5 x 20mm        | 2         |            |
| 5  | Allen Key Wrench          |    | 8mm              |           |            |
| 6  | Allen Key Wrench          |    | 4mm              |           |            |
| 7  | Phillips Head Screwdriver |    |                  |           |            |
| 8  | Spanner Wrench            |    | 15mm             |           |            |
| 9  | Left Krank Handle         |    | 100 x 100 x 35mm | 1         |            |
| 10 | Right Krank Handle        |    | 100 x 100 x 35mm | 1         |            |
| 11 | Seat Assembly             |   | 130 x 85 x 80mm  | 1         |            |
| 12 | Bottle Holder             |  | 130 x 85 x 80mm  | 1         |            |

### 2.3 ASSEMBLY STEPS

#### • ATTENTION

Prior to assembling the KRANKcycle™, unpack all of the contents of the box and make sure that all necessary components are present. Review the contents of the hardware package for completeness. Contact your local distributor or go to [www.matrixfitness.com](http://www.matrixfitness.com) to report any missing items.

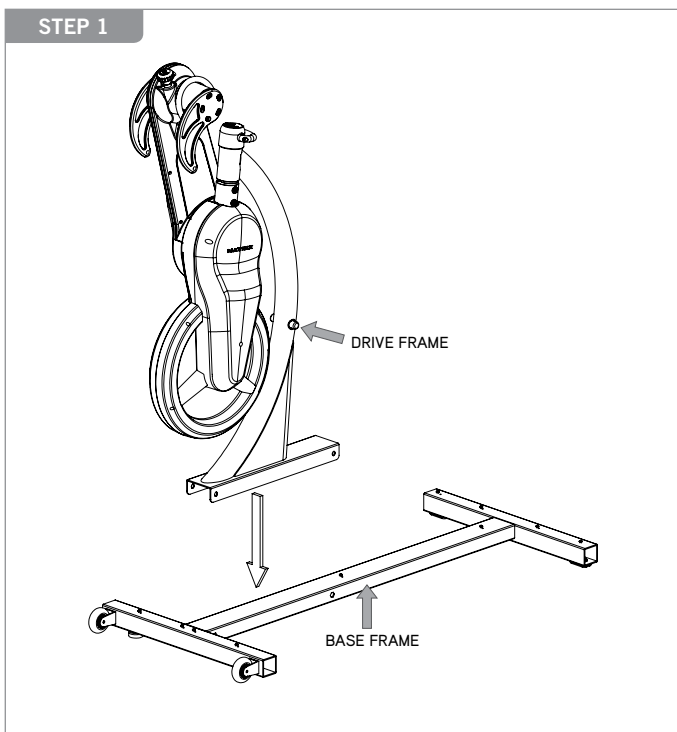

Place **DRIVE FRAME** on **BASE FRAME** so the bolt holes line up.

**IMPORTANT:** Due to the size and weight of the drive frame, the manufacturer recommends using two people to lift and place the drive frame on the base.

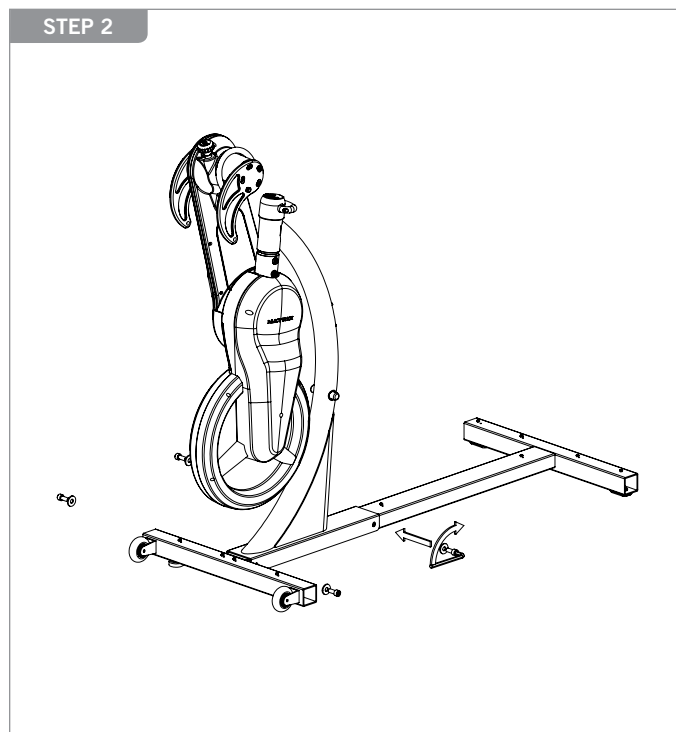

Attach the **DRIVE FRAME** to the **BASE FRAME** using **8mm ALLEN KEY WRENCH** and item **1-FLAT WASHER** and item **2-SOCKET HEAD CAP SCREW**.

### 2.3 ASSEMBLY STEPS

#### STEP 3

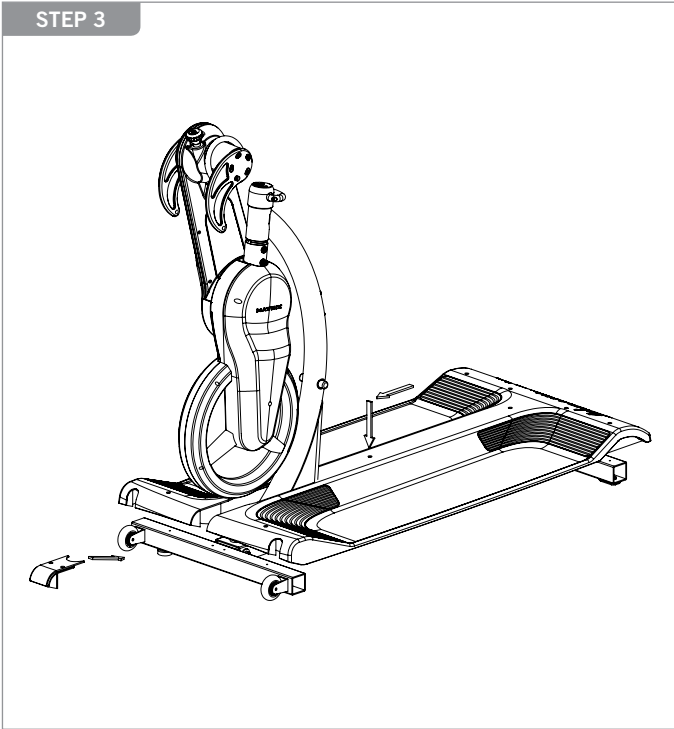

Place **SMALL BASEPLATE FRONT COVER** and **LARGE MAIN BASE PLATE** on metal frame.

#### STEP 4

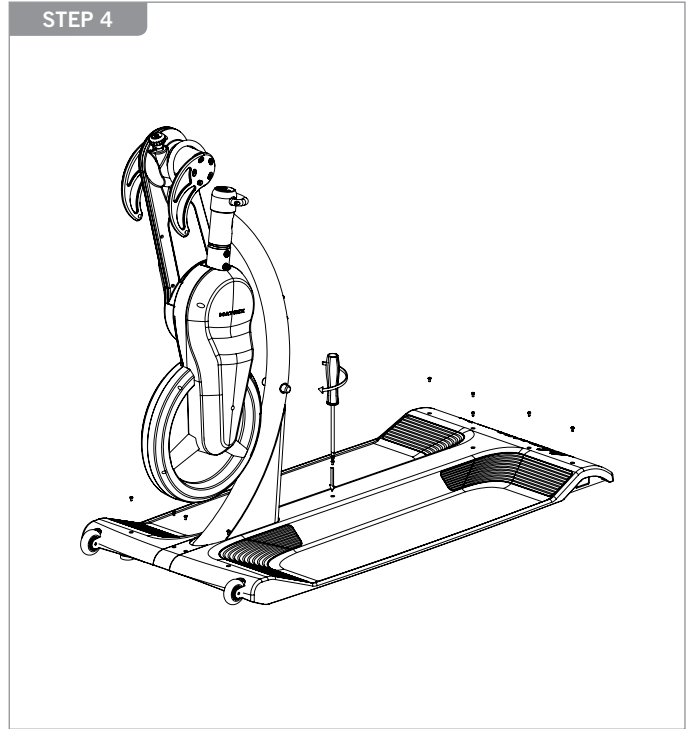

Secure **BASE PLATE** to **BASE FRAME** from step 3 with item **3-PHILLIPS HEAD SCREW** and **PHILLIPS HEAD SCREW DRIVER**.

### 2.3 ASSEMBLY STEPS

#### STEP 5

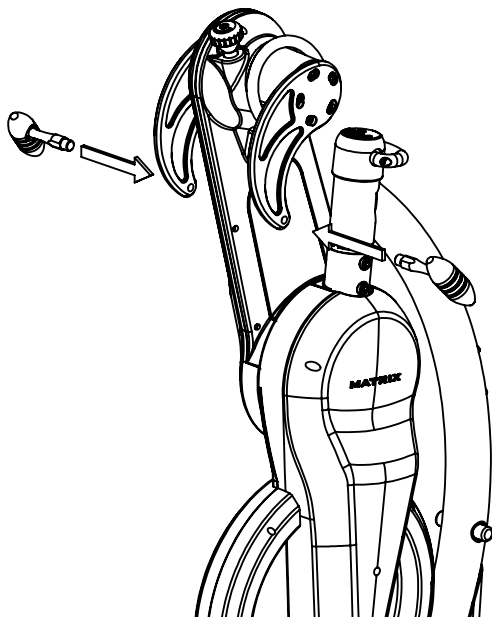

Attach **LEFT HANDLE** to **LEFT CRANK ARM** and **RIGHT HANDLE** to **RIGHT CRANK ARM**. Please note the **LEFT HANDLE** has a left hand thread.

#### STEP 6

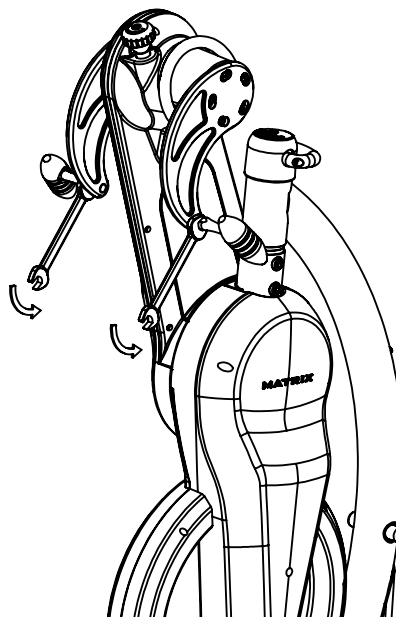

Secure **HANDLES** tightly to **CRANK ARMS** using a **15mm WRENCH**.

### 2.3 ASSEMBLY STEPS

#### STEP 7



Attach **WATER BOTTLE CAGE** to **CENTER UPRIGHT FRAME** with **4mm ALLEN KEY WRENCH** using item **4-SOCKET HEAD CAP SCREWS**.

#### STEP 8

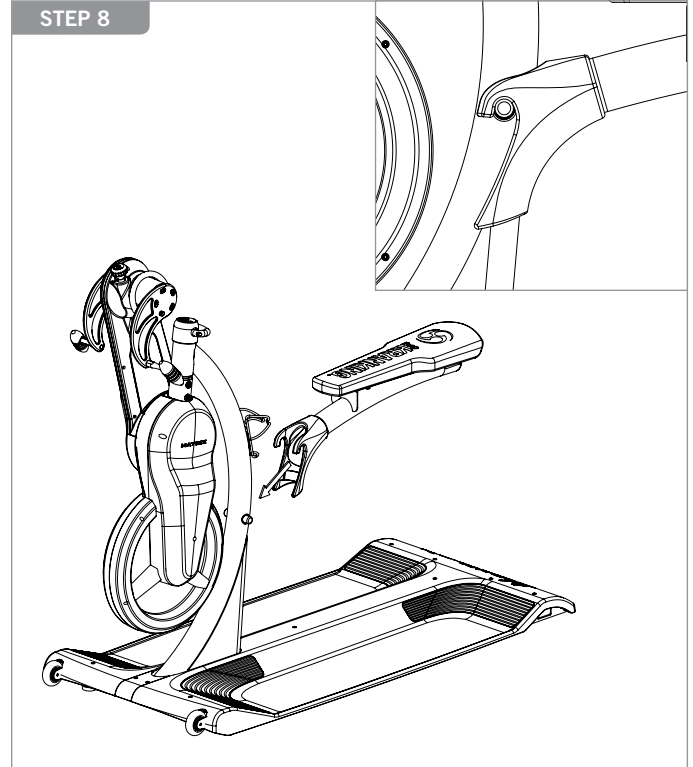

Attach **SEAT** to **UPRIGHT FRAME** by securely placing **SEAT HOOKS** around **PROTRUDING PIN**.

**!WARNING!** Make sure seat hooks are fully engaged around protruding center pin.

## ASSEMBLY COMPLETE

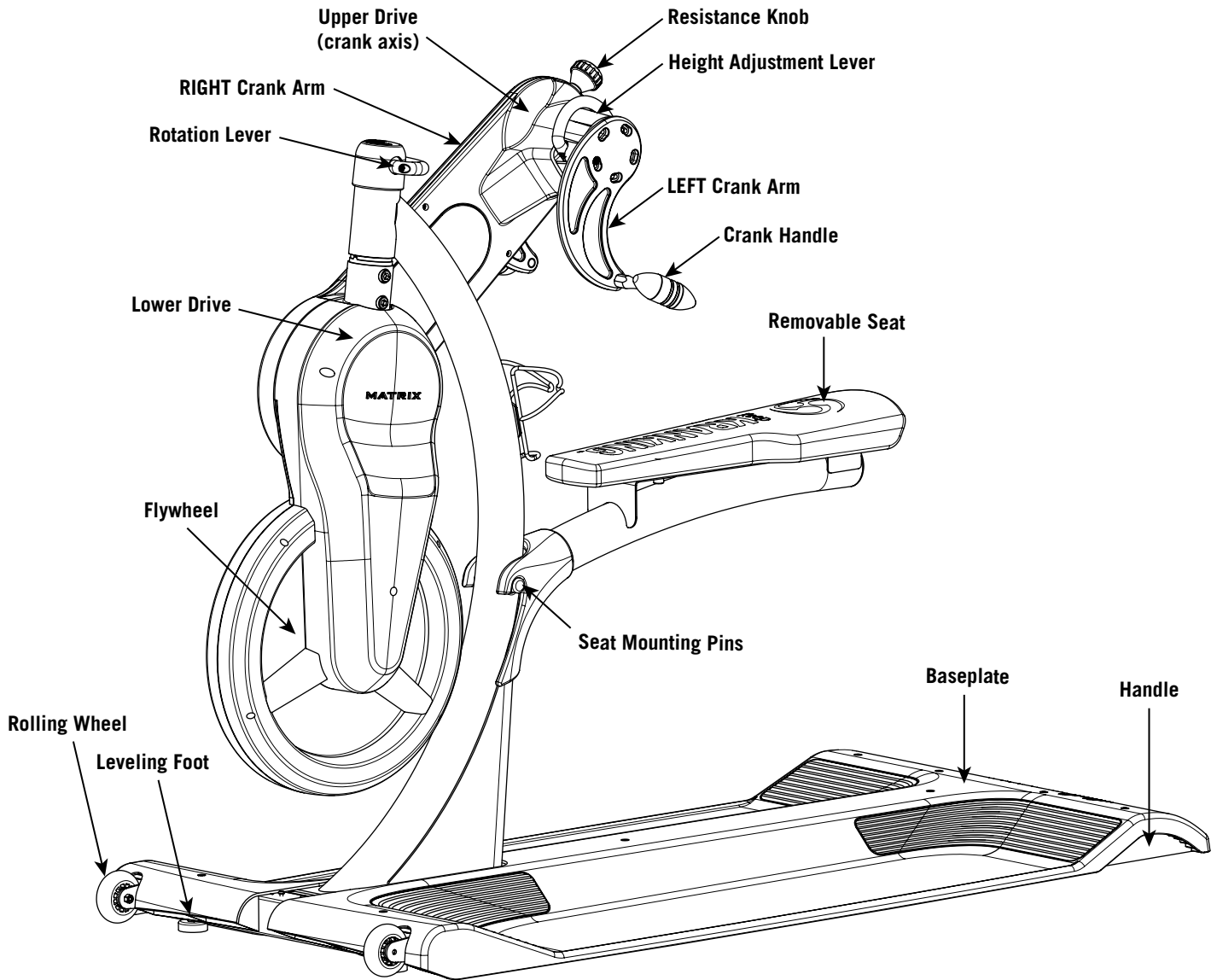

## 4.1 PROPER SET UP

The KRANKcycle™ was designed explicitly for upper body and cardiovascular training. To maximize exercise effectiveness and comfort, the KRANKcycle should be adjusted for each user and exercise position. The instructions below describe one approach to adjusting the cycle to ensure optimal user comfort and ideal body positioning: you may choose to adjust the cycle differently.

### CRANK HEIGHT ADJUSTMENT

While seated on the KRANKcycle™, grab the upper crank axis with both hands, press the height adjustment lever towards the outer edge of the crank axis, lifting or lowering the crank axis until it is in line with the center of the chest. Release the lever to lock into position. Crank handles should not hit the thigh when rotated.

**!WARNING!** Make sure height adjustment mechanism is locked into position before you begin Kranking.

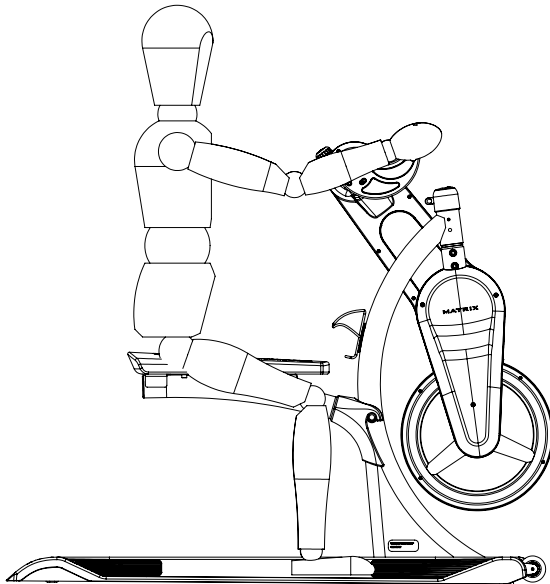
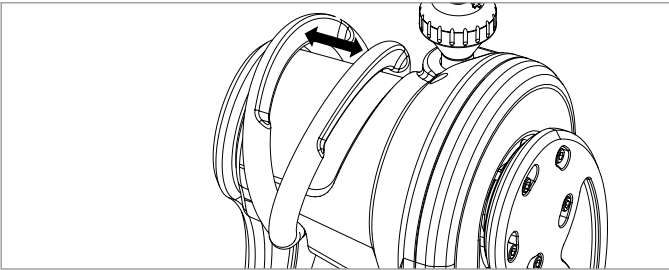

With your back straight, position yourself on the saddle so that there is a slight bend in the elbow when the crank arm is in the furthest position away from the body.

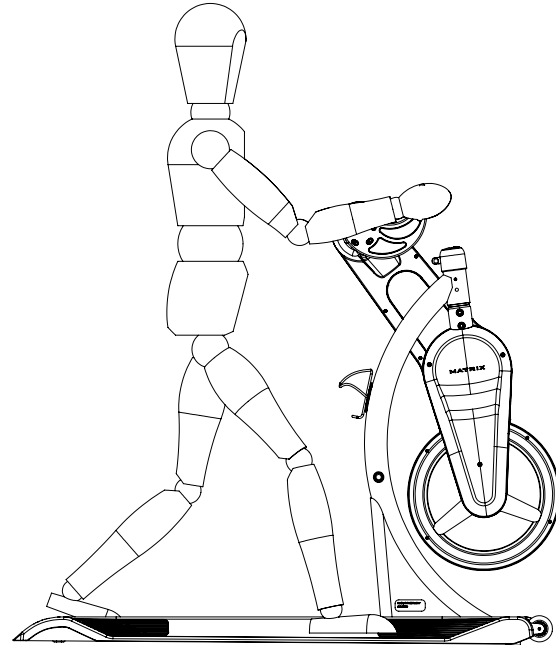

To Krank while standing, first remove the seat and set aside. Stand with your back straight and your feet shoulder width apart. Position yourself so there is a slight bend in the elbow when the crank arm is in the furthest position away from the body. Adjust the crank height if necessary.

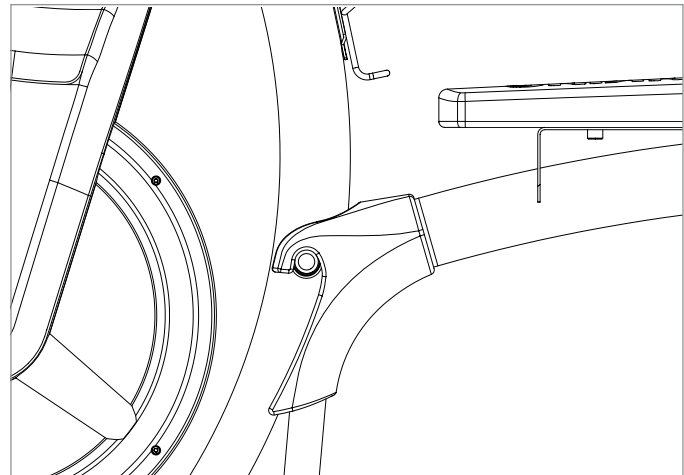

**!WARNING!** When replacing the seat be sure the hooks are fully engaged around protruding center pin.

## 4.2 HOW TO OPERATE

**!WARNING!** Do not operate this cycle with 2 people, equipment is designed for individual use. Please stay clear of moving parts and place both hands on the crank handles while exercising. Stop your workout in the event a person is within reach of moving parts.

Recommended cadence while exercising should be 60-90 RPM and the user should never operate without resistance applied.

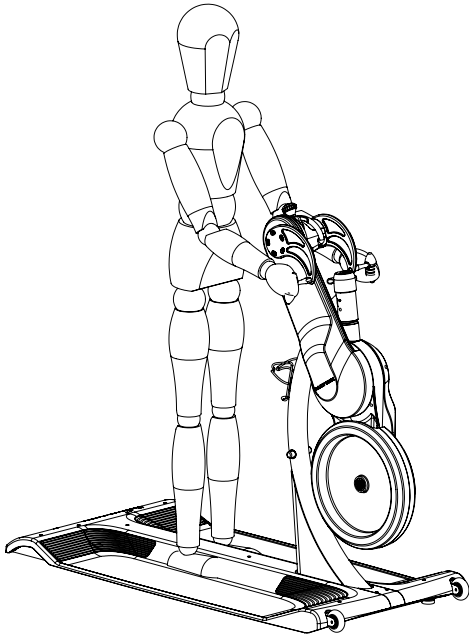

### RESISTANCE ADJUSTMENT

The preferred level of difficulty in Kranking (resistance) can be regulated in fine increments by use of the resistance knob. To increase the resistance, turn the resistance knob toward the "+" sign; to decrease the resistance, turn the knob toward the "-" sign.

**IMPORTANT:** To stop the flywheel (wheel) while Kranking, turn the resistance knob toward the "+" sign until flywheel stops.

**!WARNING!** The flywheel will continue to move even after you stop Kranking. Always Krank in a controlled manner and adjust your desired cadence and resistance according to your own abilities.

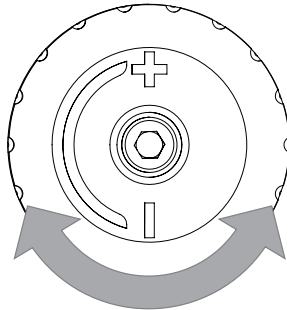

### CHANGE CRANK ARM DIRECTION

To bring cranking direction from forward or reverse, bring crank arms to top position, release rotation level, turn drive frame 180° and lock rotation lever back into place (toward the word lock) and pivot crank arms back toward user.

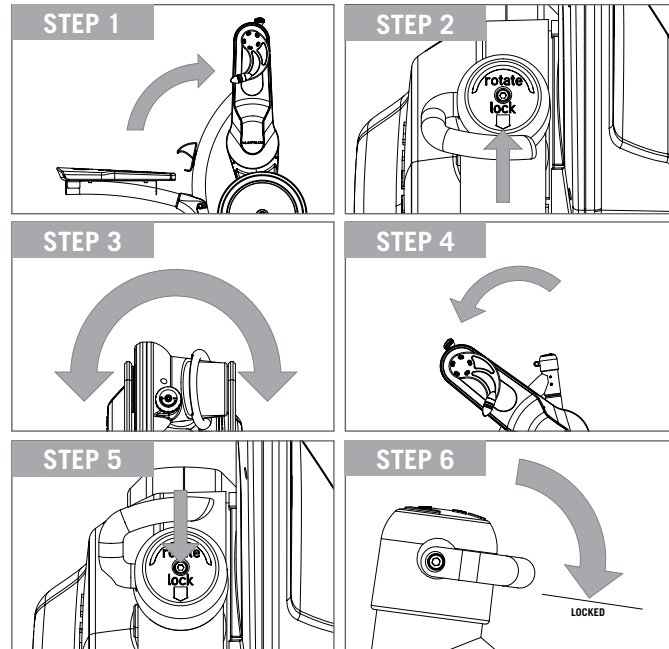

**!WARNING!** Make sure rotation adjustment lever is locked before you begin Kranking. Make sure that no components or devices block the users movement.

### 4.3 HOW TO MOVE

Bend your knees and lift the rear base of the KRANKcycle™ using the integrated grips on each side of the base. Carefully move the cycle to the desired location and then lower it. **CAUTION:** To reduce the risk of injury, use extreme caution while moving the KRANKcycle™. Do not attempt to move it over uneven surfaces and make sure you allow for a minimum of 20 inches to the nearest equipment. When lifting the front of the unit, grab the metal frame only – not the plastic base.

If the KRANKcycle™ rocks on the floor after being set down, turn the leveling feet (see diagram) underneath the front stabilizer until the rocking motion is eliminated.

**IMPORTANT:** Please do not unscrew the leveling feet more than ½ inch!

**!WARNING!** The KRANKcycle should be installed on a stable base and properly leveled before use.

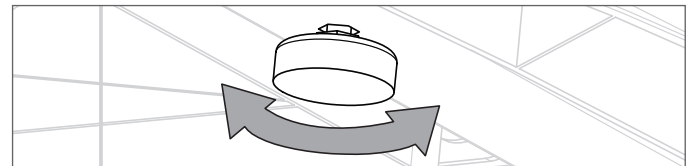

## 5.1 JOHNNY G KRANKcycle™ by MATRIX

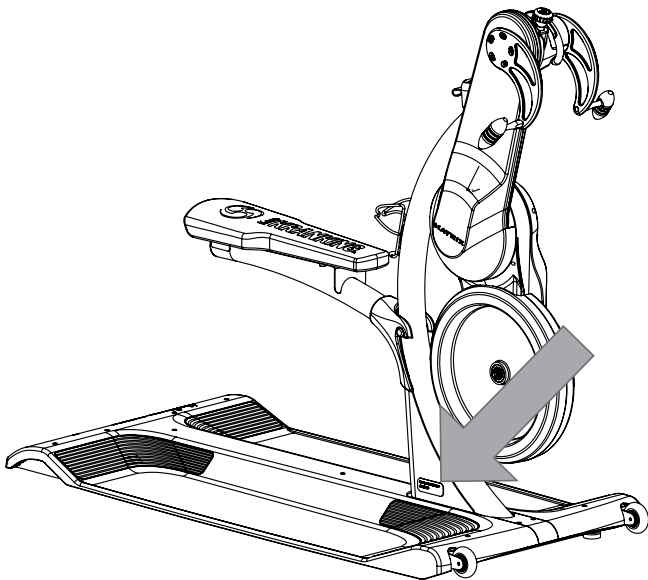

**!WARNING!** Regular maintenance must be performed on the KRANKcycle™ for optimal performance and longevity. Please read and follow all instructions below. If the cycle is not maintained as described, components may wear excessively and the cycle may become damaged. Improper maintenance will void the warranty terms. If you have questions about maintenance, contact your local distributor or go to [www.matrixfitness.com](http://www.matrixfitness.com).

Note: Many maintenance procedures require lubricant (ex. brake pad, chains, and sprockets). MATRIX recommends 3-IN-ONE oil.

## 6.1 DAILY MAINTENANCE

1. Make sure that the KRANKcycle™ is level. If it rocks on your floor, turn the leveling feet underneath the front stabilizer until the rocking motion is eliminated (see page 11).
2. After each use, the cycle should be disinfected and cleaned to maintain a hygienic environment. Clean cycle with mild soap and water or other non-ammonia based all purpose cleaners. Apply cleaner to lint free cloth and wipe crank handles, adjustment knobs and levers, base plate and the seat. Do not pour liquids directly onto the equipment. Maintain a clean environment around the cycle, free of dust and dirt.

## 6.2 WEEKLY MAINTENANCE

1. Apply a small amount of mild soap and water or other non-ammonia based all purpose cleaner to a lint free cloth and thoroughly clean the frame, crank handles, adjustment knobs and levers, seat, flywheel, baseplate and plastic covers.
2. Check regular functions of cycle and consult the **TROUBLESHOOTING GUIDE** (see page 13) if any problems exist.

## 6.3 MONTHLY MAINTENANCE

1. For optimal performance of the resistance system the following steps should be taken:
  - a. Remove lower inside plastic cover by removing 6 socket head cap screws with a 3mm ALLEN KEY WRENCH.

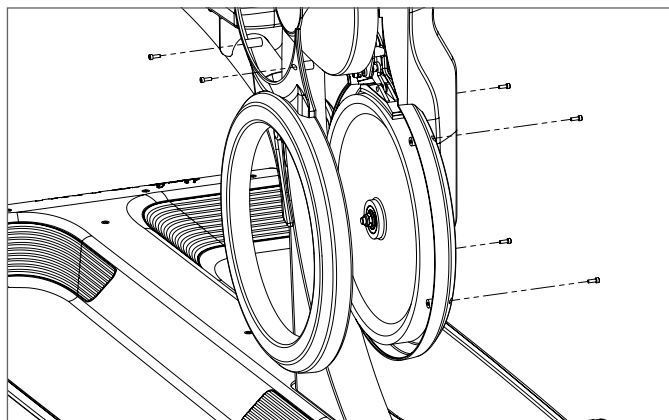

b. Check brake pad setting by first turning the resistance knob toward the “-” sign as far as it will go (minimum braking effect). The brake pad should have approximately a credit card thickness between it and the flywheel and the brake pad should feel slightly loose around its pivot. If adjustment is required see **TROUBLESHOOTING GUIDE** (see page 13).

c. Check brake pad for signs of wear and the presence of lubrication. If the brake pad requires lubrication, first adjust the resistance knob so the brake pad is just slightly touching the flywheel. Then slowly rotate the flywheel with one hand while applying a small amount of lubricant on the flywheel just behind the brake pad (A) on the in-going side. Wipe off excess.

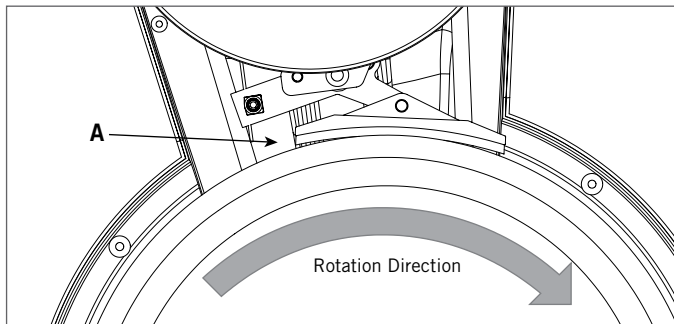

- d. Replace brake pad if necessary
- e. Replace lower inside plastic cover

2. Check and tighten (if necessary) the screws on crank arms, adjustment knobs and levers, seat, water bottle holder, and plastic covers.

### 6.4 BI-YEARLY (6 MONTH) MAINTENANCE

1. For optimal performance of the drive system the following steps should be taken:

- a. Remove the RIGHT crank arm by removing 5 socket head cap screws with a 4mm ALLEN KEY WRENCH then remove the upper outside plastic cover by removing 5 socket head cap screws with a 3mm ALLEN KEY WRENCH. Then remove both of the lower plastic covers by removing 9 socket head cap screws with a 3mm ALLEN KEY WRENCH and 5mm ALLEN KEY WRENCH.

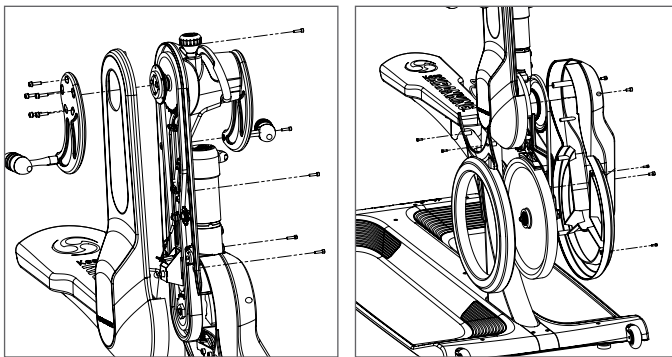

- b. Thoroughly wipe down around all internal components and look for signs of excessive wear or damage.
- c. Lubricate both upper and lower drive chains. Clean excess.
- d. Replace drive chains if necessary
- e. Replace all plastic covers and RIGHT crank arm

### 6.5 TROUBLESHOOTING GUIDE

Follow the steps below if any problems are discovered in the weekly function test.

#### CRANK ARMS NOT SYNCHRONIZED

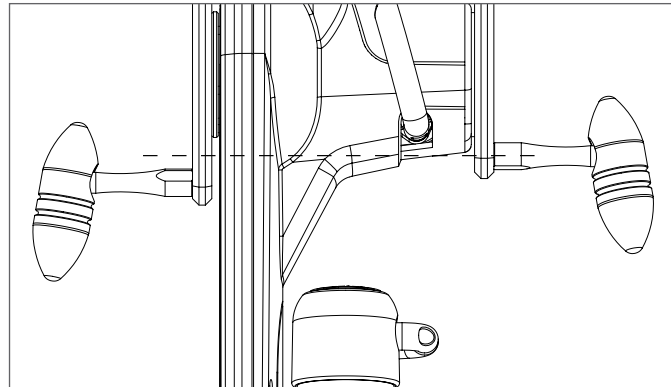

Turn the resistance knob toward the “+” sign until the crank arms do not fall by themselves back to the lowest rest position. Raise the crank arms so the crank handles are nearly level. Loosen (do not remove) the 5 socket head cap screws (B) on the RIGHT crank arm with a 4mm ALLEN KEY WRENCH. Adjust the position of screws within the slots until both crank handles are level and then tighten. Make sure all screws are tight, or the crank handle may slip out of synchronization again.

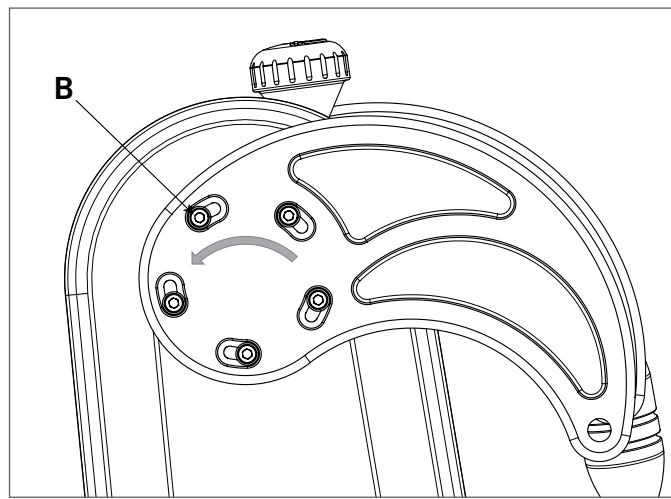

## UPPER DRIVE ARM EXHIBITS EXCESSIVE SIDE-TO-SIDE PLAY

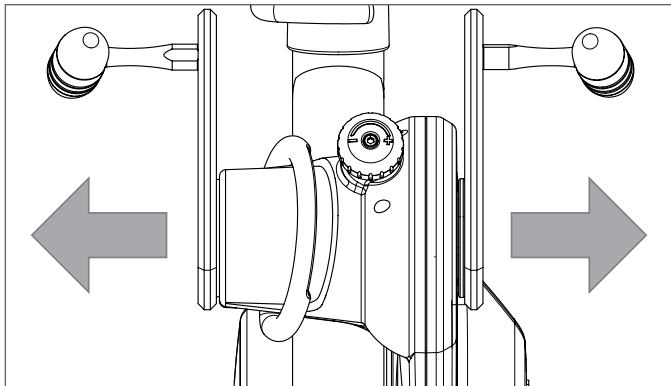

Check if rotation lever is fully engaged (A). If so, follow next steps.

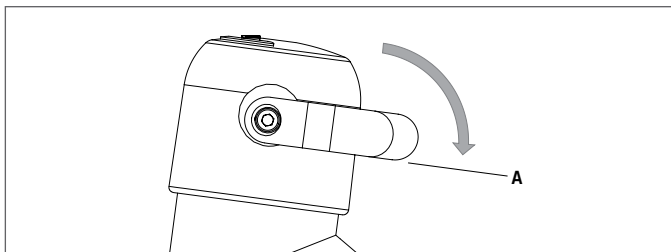

Remove rotation lever and cap by removing 2 socket head cap screws with a 4mm ALLEN KEY WRENCH. Loosen (do not remove) upper set screw (B) on upright frame with a 3mm ALLEN KEY WRENCH.

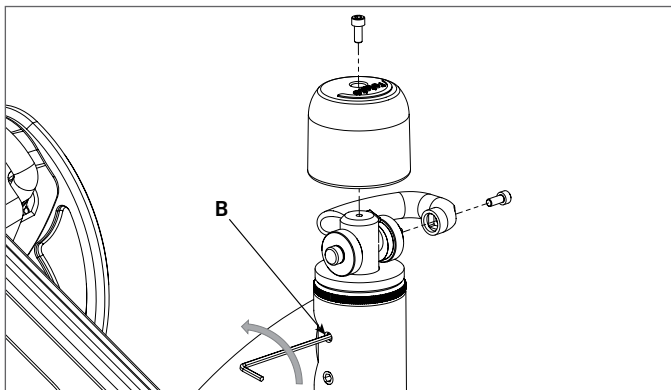

Replace rotation lever, and release rotation cam mechanism (C). Rotate cam plate (D) counterclockwise 1/8 of a turn and then engage rotation cam mechanism. Repeat until the upper drive arm is held rigidly without play. The rotation lever should require a firm force to fully engage. If the rotation lever is too difficult to engage, reverse the previous steps.

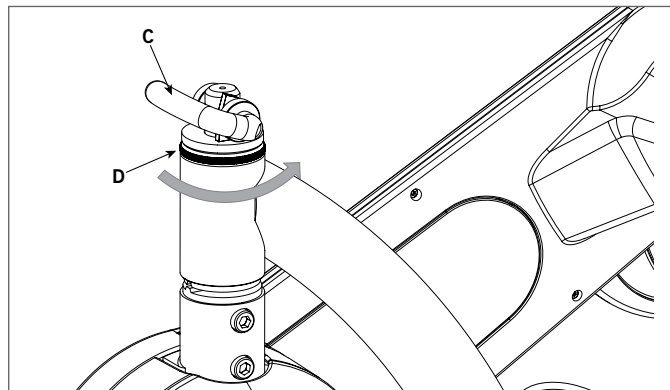

To complete adjustment tighten upper set screw and replace rotation lever and cap.

## ROTATION LEVER POPS UP WHILE THE CYCLE IS IN USE

If the rotation lever loosens or pops up while the cycle is in use, perform the maintenance suggestions for "UPPER DRIVE ARM EXHIBITS EXCESSIVE SIDE-TO-SIDE PLAY"

## EXCESSIVE PLAY IN PIVOTING HEIGHT ADJUSTMENT LEVER

It is normal for the lever to exhibit a small amount of play before the upper drive arm is disengaged, but if the lever has excessive play (E) or the lever is pulled to its full extent and there is a pronounced clicking noise when the upper drive arm is rotated, then follow the next steps.

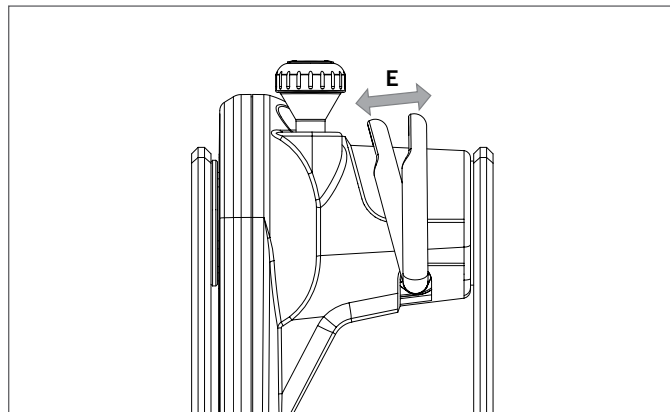

Remove the RIGHT crank arm by removing 5 socket head cap screws with a 4mm ALLEN KEY WRENCH then remove the upper outside plastic cover by removing 5 socket head cap screws with a 3mm ALLEN KEY WRENCH.

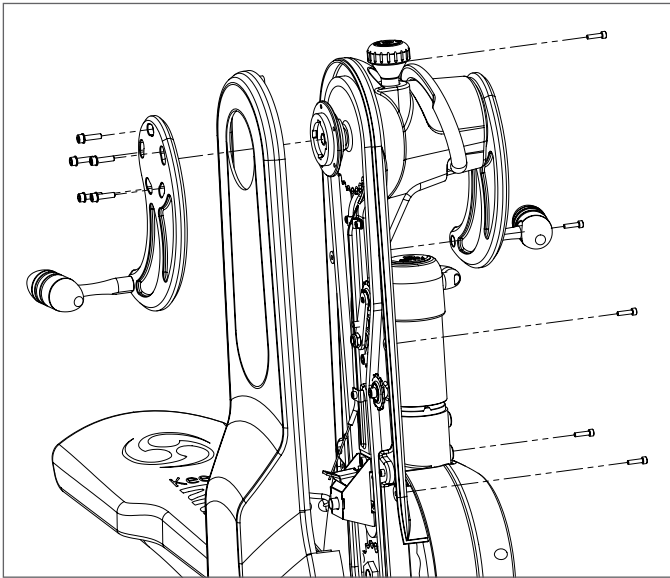

Check cable and cable sheath (A) for excessive wear (replace if necessary). If the lever still exhibits excessive play, tighten the adjustment screw (B) clockwise until play is removed. Be careful not to over tighten the adjustment screw as the pivoting mechanism may not fully engage and could lead to machine failure or injury.

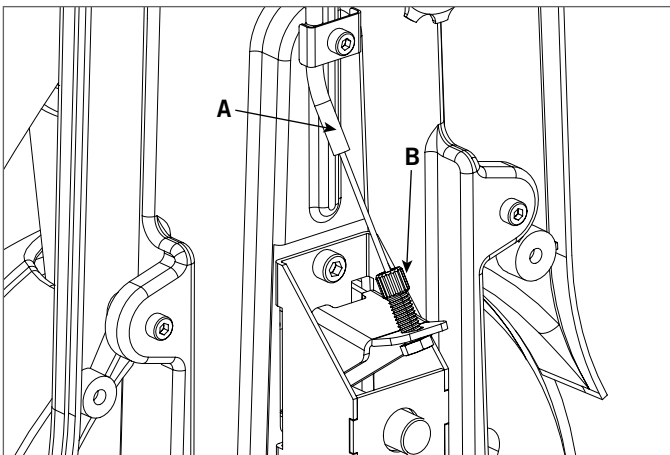

Replace upper outside plastic cover and **RIGHT** crank arm

### FLYWHEEL RESISTANCE TOO HARD EVEN WHEN REDUCED TO THE MINIMUM, OR RESISTANCE KNOB REQUIRES TOO MANY TURNS BEFORE BECOMING HARDER

To adjust the brake pad setting, first remove the lower inside plastic cover by removing 6 socket head cap screws with a 3mm ALLEN KEY WRENCH.

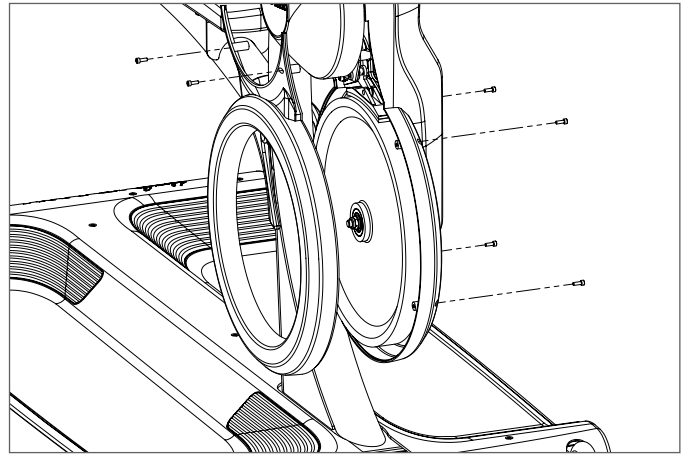

Loosen (do not remove) the brake cable screw (C) and turn the resistance knob toward the “-” sign as far as it will go (minimum braking effect). Then turn the knob toward the “+” sign 1 full revolution. Make sure the brake pad is pressed against the flywheel, and then secure the brake cable under the brake cable screw (C). Turn the resistance knob toward the “-” sign as far as it will go, the brake pad should have approximately a credit card thickness between it and the flywheel.

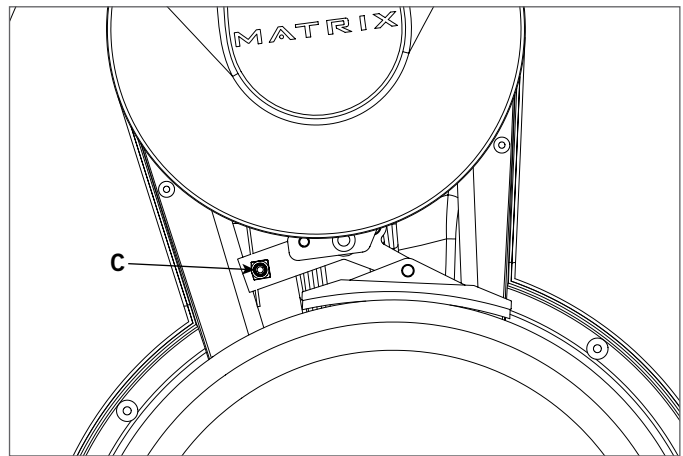

Replace lower inside plastic cover.

## UPPER CHAIN DRIVE MAKING A PRONOUNCED CLICKING NOISE

Over time, it is normal for the drive chains to stretch with use. The KRANKcycle™ is equipped with automatic chain tensioning devices, but the chain may need to be replaced if it has stretched too far. Follow the next steps to check for excessive chain wear or stretch. If the chain needs to be replaced, contact MATRIX customer service.

Remove the RIGHT crank arm by removing 5 socket head cap screws with a 4mm ALLEN KEY WRENCH then remove the upper outside plastic cover by removing 5 socket head cap screws with a 3mm ALLEN KEY WRENCH.

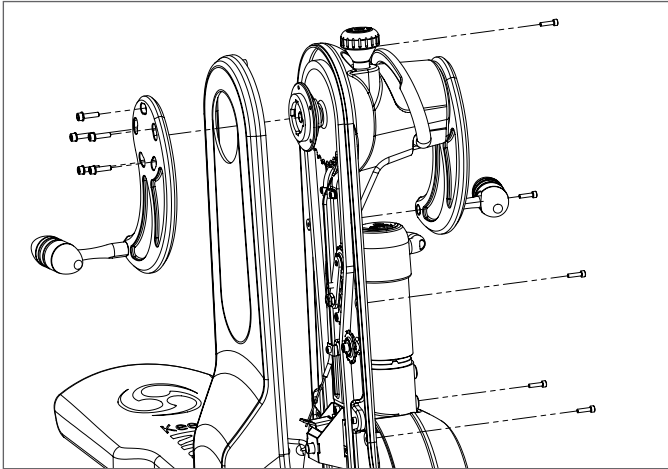

If the chain is rubbing on the inside covers the chain should be replaced by a service technician

Replace upper outside plastic cover and RIGHT crank arm

## LOWER CHAIN DRIVE MAKING A PRONOUNCED CLICKING NOISE

Over time, it is normal for the drive chains to stretch. The KRANKcycle™ is equipped with automatic chain tensioning devices, but the chain may need to be replaced if it has stretched too far. Follow the next steps to check for excessive chain wear or stretch.

Remove both of the lower plastic covers by removing 9 socket head cap screws with a 3mm ALLEN KEY WRENCH and 5mm ALLEN KEY WRENCH.

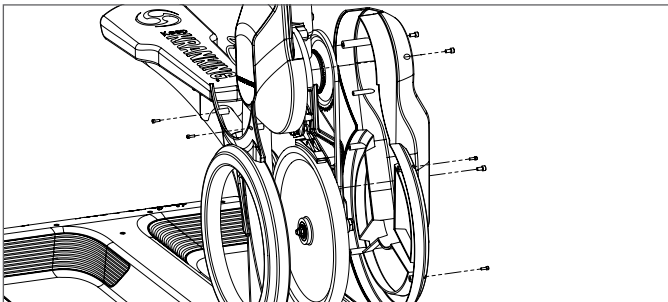

If the chain is rubbing on the inside covers or exhibits too much play around the sprockets the chain should be replaced by a service technician.

Replace both lower plastic covers.

## CYCLE DIFFICULT TO PUSH WHEN MOVING

The front rolling wheels may need lubrication. Remove both wheels by unscrewing the nut and bolt. Lubricate the outside of steel axle tube (A). Replace both wheels using a 10mm WRENCH.

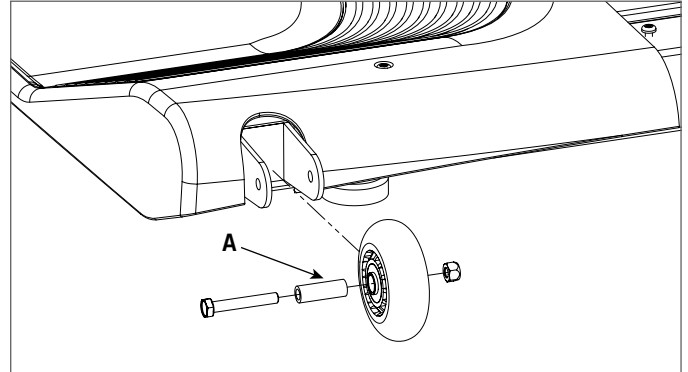

## RESISTANCE KNOB DOES NOT ROTATE SMOOTHLY

The resistance cable mechanism may need lubrication. Remove the resistance knob by removing the 1 socket head cap screw with a 4mm ALLEN KEY WRENCH. Lubricate the cable mechanism (B) through the opening in the plastic cover. Replace the resistance knob.

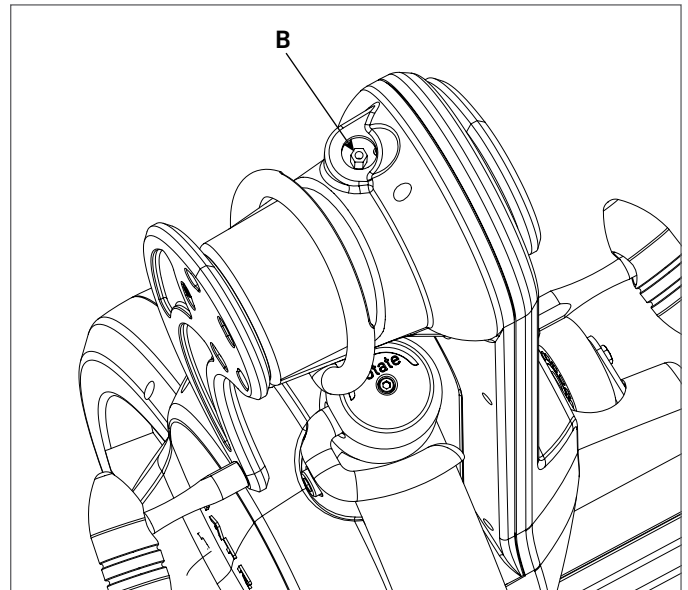







Strong. Smart. Beautiful.

MATRIX FITNESS SYSTEMS | 1610 LANDMARK DRIVE COTTAGE GROVE WI 53527 USA  
Toll Free 866.693.4863 [matrixfitness.com](http://matrixfitness.com) Fax 608.839.8687

MODEL # MFC0002-0S

REV. 1.0