



215 - 12th Avenue NE
Valley City, ND 58072-0905

1-800-437-8011
triwg@triwg.com
www.triwg.com

FOR CUSTOMER ASSISTANCE

As a future reference, we suggest you record the information listed below for quick accessibility.

Model No.: _____

Serial No.: _____

Purchase Date: _____

Purchased From: _____

Tri W-G® Service:
1-800-437-8011
triwg@triwg.com

 **USER MANUAL**

P/N: 920-002-024

For

Bariatric Hi-Lo Table

TWG.8.1.00.BTM, TWG.8.2.00.BTM & TWG.8.3.00.BTM Series



Read this manual before installing, operating, or maintaining this table. Failure to follow safety precautions and instructions could cause a system failure and result in serious injury, death or property damage.

LIMITED WARRANTY REGISTRATION CARD ENCLOSED

TABLE OF CONTENTS



INTRODUCTION2

1.0 RECEIVING INSPECTION2

2.0 UNCRATING2

3.0 INSTALLATION2

4.0 SAFETY/PRECAUTIONARY INSTRUCTIONS3

5.0 INTENDED USE4

6.0 INTENDED USER PROFILE4

7.0 OPERATING INSTRUCTIONS4

8.0 MAINTENANCE5

9.0 SYMBOLS, INDICATORS, and DEGREE OF SAFETY6

10.0 WARNINGS and USAGE HINTS7

11.0 OTHER HAZARDS7

12.0 SPECIFICATIONS8

13.0 STARTUP CONDITIONS8

14.0 OPERATING CONDITIONS9

15.0 STORAGE CONDITIONS9

16.0 TRANSPORT CONDITIONS9

17.0 NOTICE9

18.0 TROUBLESHOOTING9

19.0 REPLACEMENT PARTS LOCATION SCHEMATIC10

19.1 REPLACEMENT PARTS11

20.0 DISPOSAL12

WARRANTY13

DISCLAIMER14

INTRODUCTION

The purpose of the User Manual is to introduce the authorized user to the operating instructions on how to use and work with this medical device safely, and to conduct routine preventative maintenance procedures on the device. For this goal to be achieved, it is essential that all the authorized users/operators (“user”) read this manual carefully, and understand and practice the precautionary safety measures recommended in it. The owner and/or operating authority determines who the user is.

ANYONE OPERATING THIS DEVICE MUST READ THIS USER MANUAL.

1.0 RECEIVING INSPECTION

1.1 Inspect for visible damage of the container. If there is outside damage, note on the shipping documents, and report to commercial carrier. Determine whether or not to accept or refuse the container. Sign if appropriate.

2.0 UNCRATING

2.1 Upon acceptance of the container, inspect for any damage to the device immediately following uncrating. In the event the device is damaged, file a merchandise damage report immediately with the delivering carrier. **DO NOT** return damaged merchandise to Tri W-G® unless instructed to do so. Call for a Return Authorization Number prior to returning any merchandise.

2.2 Keep the cardboard liner on top of the table while moving treatment table to the desired location. This will prevent damage to the frame and/or cushion while moving the table down hallways, through doorways, etc.

2.3 Remove all other packaging material from the table, except for the cardboard cushion liner/protector.

2.4 Properly dispose of/or recycle all packaging material.

3.0 INSTALLATION

3.1 **WARNING! Excessive Weight Hazard.** Use appropriate pallet jack(s), lifting devices, and/or equipment, adequate to lift approximately 700 lbs minimum, and we recommend four or more people to move table. Failure to do so may result in personal injury, death, and/or property damage. When moving the table to its desired location, use proper moving/lifting techniques and/or body mechanics per commercial carrier and/or the facility handling protocol or guidelines; this due to its immense weight and overall size.

3.2 There is no assembly required.

3.3 The treatment table should be placed in a location based on its intended use. Position the table in an area having flat/level floors so that the table is not distorted out of alignment. By following this instruction, the twin wheel casters with locking brakes will function as intended to achieve maximum stability.

3.4 All four (4) of the twin wheel total locking casters should have their wheels locked at all times except for moving. **DO NOT** move the table with a patient on the table.

- 3.5 Connect or plug-in the power cord to a properly grounded 120 Volt AC receptacle, conforming to the relevant state and nationally recognized electrical codes, and follow the procedure outlined in the Safety/Precautionary Instructions.
- 3.6 The power supply cord serves as a disconnect device or as the on/off switch. Do not unplug by pulling on the cord. To unplug, grasp the plug, not the cord. **DO NOT** handle plug with wet hands. The receptacle shall be installed near the table and shall be easily accessible.
- 3.7 Arrange power supply cord away from the traffic area and where it will not be tripped over.
- 3.8 **DO NOT** use with an extension cord.
- 3.9 Upon connecting the power supply cord to a grounded receptacle, test treatment table to determine electrical functionality.
- 3.10 **STAY ALERT**, watch what you are doing and use common sense.

4.0 SAFETY/PRECAUTIONARY INSTRUCTIONS

4.1 Once again, please have anyone who is authorized to use this table read, understand, and practice the safety and precautionary instructions recommended in this user manual. All operators should use common sense, know and fully understand the hazards and risks associated with using and/or operating this Tri W-G, Inc. table prior to operating it.

4.2 **NEVER LEAVE THE PATIENT UNATTENDED.** Close attention is necessary when patients are children and/or disadvantaged.

4.3 Never place ones hand or feet, nor the patients' hand or feet, near any of the working mechanisms or gap areas on the table when raising or lowering the table, backrest, and/or kneegatch sections. And **DO NOT** place or leave objects or items of any kind underneath the base frame of the table at any time; example: foot stool left under table when the top frame is moving.

4.4 Whenever you see this symbol:  it signifies "Caution", and is used as a "General Warning Sign"; You and/or Your Patients' Safety is Involved.

4.5 During table operation, immediately stop the table operation, if anything unusual is observed or unusual sounds are heard coming from the table.

4.6 The SKF operating system is double insulated for protection from Electromagnetic Interference ("EMI"). The system is designed to provide reasonable protection against harmful interference in a typical medical installation. This equipment generates, uses and can radiate radio frequency energy and, if not installed and used for its intended purpose, in accordance with the instructions, may cause harmful interference to other devices in the surrounding area. Interference can lead to data loss, problems with computers, monitors, cell phones, various other wireless applications, and signal interruptions, to name a few.

The SKF operating system meets when used for its intended purpose all applicable provisions of the Low Voltage Directive 2006/95/EC and of the Directive of Electromagnetic Compatibility 2004/108/EC; Collateral Standard: Electromagnetic compatibility EN 60601-1-2, 2007 on EHA1/3, STJ, RU2, ECO, MAX3, and SCUxx (x: any alphanumeric character) for accessories and products. Used Standards are EN 60601-1, 1990 +A1+A2; EN 60601-12006; EN 60601-1-2, 2007. The SCU and VCU also meet when

used for its intended purpose ANSI/AAMI ES60601-1, "Medical Electrical Equipment-Part 1: General Requirements for Basic Safety and Essential Performance: (3rd Ed.).

However, there is no guarantee that EMI will not occur in a particular installation. If this equipment does cause harmful interference to other devices, which can be determined by turning the equipment off and on, the user is encouraged to try to correct the interference by one or more of the following measures:

- * Relocate the device.
- * Increase the separation between various devices and/or equipment.
- * Connect the device into a receptacle on a different circuit.
- * Call a facility service technician for assistance.

4.7 **DO NOT** use this table to play on or as a play area, no matter what the age of the patient or individual may be. It is a Class I Medical Device, called a treatment table. And **DO NOT** store or allow any object, of any kind, under the table at any time. No medical claims are made with regard to a patient using the device. Tri W-G,[®] Inc. shall not be liable for any damage, death or injury caused, directly or indirectly, from the misuse of this device/table; and the user shall indemnify Tri W-G,[®] Inc. from and against all costs, damages and expenses (including legal expenses) arising from any such misuse.

5.0 INTENDED USE

It is a powered table intended for medical purposes (Class I Device) that is an electrically operated flat surface table that can be adjusted to various positions. It is used by patients with circulatory, neurological, or musculoskeletal conditions to increase tolerance to an upright or sitting position; [21CFR890.3760]. At no time should patients be left unattended on the table.

6.0 INTENDED USER PROFILE

It is intended to be used by Licensed Physical Therapists, Assistant Physical Therapists, Occupational Therapists, Assistant Occupational Therapists, and licensed rehab specialists utilizing a prescribed therapeutic protocol, written by a licensed medical practitioner or physician. It is not intended to be used by maintenance staff, installers, patients and/or lay persons.

7.0 OPERATING INSTRUCTIONS

7.1 **Adjust Height**--To raise or lower the table, simply touch the up or down arrow key on the hand switch. The low voltage hand set has operating power of VDC/mA of 12/50.

7.2 **Duty Cycle**--System is an intermittent operation; 1 minute on, 9 minutes off.

7.3 **Capacity**--The table is intended to support **750 lbs** (340 Kilograms), evenly distributed over the table top.

7.4 **Casters, Standard**--This standard caster is a twin wheel total locking caster. It is a mobile and transportable treatment/mat table, and may be moved from one location to another with the aid of the supporting twin wheel casters. No patient(s) and/or individuals whatsoever are allowed on the table during transportation of the table. The casters are only used for the purpose of moving the table from one place to another. Once the table is positioned on a level area, in its dedicated working place, totally lock all four casters. Activating the total locking caster is accomplished by placing foot on the trailing end of the caster housing and step down on the locking mechanism paddle. To unlock the casters, place foot on the front raised portion of the caster housing locking step pad and push down. **DO NOT** position the

treatment/mat table on an uneven floor area that may twist/distort the table frame; as it may put the lifting mechanism in a stressed state, shortening the lifespan of the table. **ALWAYS** lock all four (4) casters during use of the treatment/mat table, except for moving.

7.5 **Hi-Lo, Adjusting**--use the handset and press the up or down key to operate. Always check to make absolutely sure there are no objects under the table or near the top frame when lowering or raising the table. It takes very little time to make a second check if you have left the area prior to your next hi-lo adjustment. Never leave the table with a patient on it. An example of an object that can easily make its way under the table is a step stool; and there are many more objects that lie around or are near a table that can get shoved under the table.

7.6 **Table Section, Adjusting w/Patient**--**DO NOT** place the patients' entire weight or body on a specific section of the table that you are going to adjust. The backrest is for the back, not the patients' entire body, and carries a maximum static uniform load on the backrest of 225 lbs. Same goes for the kneegatch section. It also carries a maximum static uniform load on the kneegatch section of 225 lbs. Make sure all hands, arms, feet or other objects are not in the table gap areas.

7.7 **User**--**Never** allow the patient to operate the treatment table. Only trained personnel authorized to use the table should operate the treatment table.

8.0 **MAINTENANCE**

8.1 The table is equipped with a state-of-the-art linear actuator system, having a lifespan for each component of the system as follows: The VCU Control Unit (Tri W-G® PN 900-010-110) has a lifespan of approximately 10 years or 100,000 double-strokes. The VCU Control Unit is only suitable for inside applications and must not be subjected to weathering strong UV radiation or corrosive or explosive air. The linear actuator RUNNER™ (Tri W-G® PN 900-010-103) is designed for a life of approximately 10 years or 20,000 double-strokes (with authorized usage). The Ecomag (Tri W-G® PN's 900-010-107 and 900-010-109) has a service life of approximately a maximum of 10,000 double-strokes with a stroke of 200mm or less. Double-stroke is defined as one extension and one retraction stroke combined. However, conducting routine preventative maintenance checkups are a must. One must routinely check the actuator for wear on the end mounts and connecting bolts, for unusual noises, for actuator wobbling when extending or retracting the spindle, and that it is operating smoothly, as minimums. Due to normal wear, it may be necessary to replace the linear actuator during the lifespan of the table. The actuator is not-servicable in the field. Call customer service for a replacement actuator.

8.2 Once a month, and/or as may be needed, check the actuator spindle end for a gap that looks like the one shown in photo 8.2.1 below. If this gap looks closed or like it has been crushed or squeezed, please call the Tri W-G,® Inc. Service Department at 1-800-437-8011.

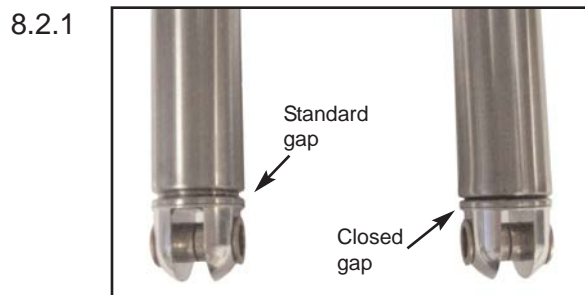

8.3 Due to normal wear, it may be necessary to replace the handset or the power cord. Call our customer service for replacement parts and/or installation instructions.

8.4 Cleaning the vinyl cover is accomplished with water and a mild detergent. Do not use Peroxide, Hylex, Lysol, strong or aggressive cleaning agents as they will discolor and reduce the life of the vinyl. The water used for cleaning, including chemical additives, must be pH-neutral. And liquids must not touch the actuator(s) during retraction or extension. A soft dust cloth will work to remove dust and lint on the steel frame when necessary. The mat table frame should be wiped down using a dry cloth to remove dust/lint on a regularly scheduled basis--keep free of dust. Cleaning the cover should be done after each patient procedure is complete and prior to new patient being placed on the table.

8.5 Inspection and maintenance/repair shall be made on a regular and/or periodic basis, which shall encompass the entire table. This includes, but is not limited to, the following: all moving parts, casters, actuators, backrest and knee gatch (if applicable), cushion (vinyl, velcro, stitching, foam), broken welds and/or cracks, bushings, nuts, bolts, screws, handset, power cord, wire holding clips and snaps, etc., to name a few. Replacement of worn or failed parts shall be replaced immediately, or as is deemed necessary. All inspections and maintenance/repair activities shall be recorded by owner facility. Operator should notify all users to discontinue using the table if the safety of operator and/or patient is eminent. Call Tri W-G,[®] Inc. Service Dept at 1-800-437-8011 and report any potential safety concerns.

8.6 Any repair should be performed by trained or certified service personnel.

9.0 **SYMBOLS, INDICATORS, and DEGREE OF SAFETY**



Mandatory action sign; Read User Manual Caution: General Warning Sign.



Mandatory action sign; Read User Manual Caution: General Warning Sign.



Read User Manual; contains useful information.



General Warning Sign.



Type B Equipment: Equipment providing a particular degree of protection against electric shock, particularly regarding allowable leakage current and reliability of the protective earth connection.



Protective Earth Ground: This product is Class I equipment in which protection against electric shock does not rely on BASIC INSULATION only, but which includes an additional safety precaution in that means are provided for the connection of the EQUIPMENT to the protective earth conductor in the fixed wiring of the insulation in such a way the ACCESSIBLE METAL PARTS cannot become LIVE in the event of a failure of the BASIC INSULATION.



Earth (ground).

WATER

Protection against harmful ingress of water--Prevent mat table from being subjected to water sprays or water hosing.

ANASTHETICS

Not suitable for use in the presence of a flammable anesthetic mixture with air or oxygen or nitrous oxide.

ELEC. RATING

Input: 110 VAC; 6.5 A Max; 60 Hz

10.0 WARNINGS and USAGE HINTS

Please make note of the meaning of the following warnings and usage hints:

Note: indicates usage information that helps the user to use the product correctly and efficiently or to understand the properties of the product.

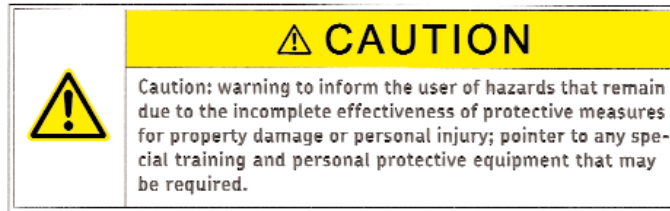

11.0 OTHER HAZARDS

The manufacturer has constructively, and with protective measures, minimized the effects of existing hazards. Pay attention to the following hazards and the possible countermeasures given in the following:



915-001-292



915-001-300



915-001-283

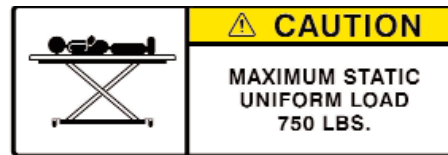

915-001-298

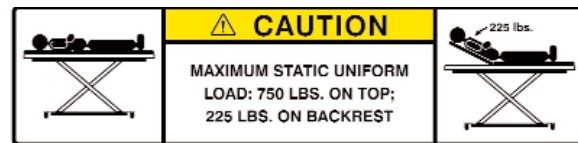

910-001-294

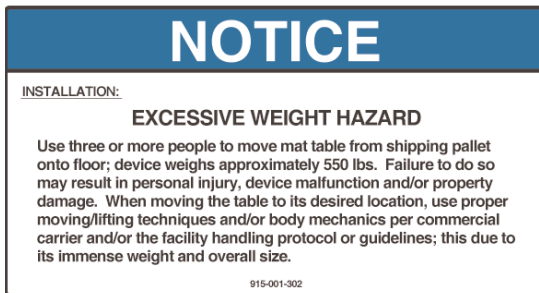

915-001-302

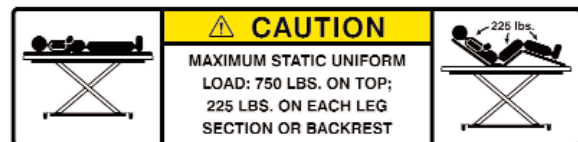

915-001-296

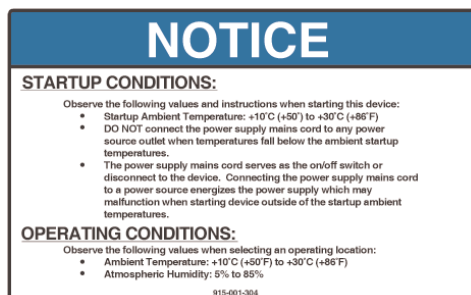

915-001-304

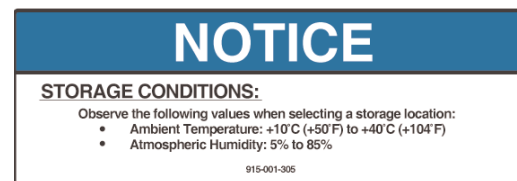

915-001-305

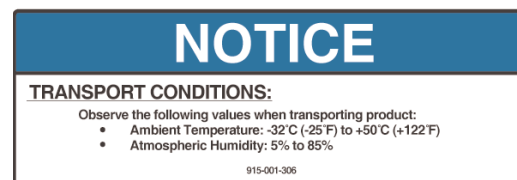

915-001-306

12.0 SPECIFICATIONS:

Item No. TWG8132.BTM:	Width-32"; Length-78"; Ht. Range- 16.0"-35.2" to table top frame/18.0"-37.2" to top of cushion <i>(heights nominal)</i>
Item No. TWG8136.BTM:	Width-36"; Length-78"; Ht. Range- 16.0"-35.2" to table top frame/18.0"-37.2" to top of cushion <i>(heights nominal)</i>
Item No. TWG8142.BTM:	Width-42"; Length-78"; Ht. Range- 16.0"-35.2" to table top frame/18.0"-37.2" to top of cushion <i>(heights nominal)</i>
Item No. TWG8148.BTM:	Width-48"; Length-78"; Ht. Range- 16.0"-35.2" to table top frame/18.0"-37.2" to top of cushion <i>(heights nominal)</i>
Item No. TWG8232.BTM:	Width-32"; Length-78"; Ht. Range- 16.0"-35.2" to table top frame/18.0"-37.2" to top of cushion <i>(heights nominal)</i>
Item No. TWG8236.BTM:	Width-36"; Length-78"; Ht. Range- 16.0"-35.2" to table top frame/18.0"-37.2" to top of cushion <i>(heights nominal)</i>
Item No. TWG8242.BTM:	Width-42"; Length-78"; Ht. Range- 16.0"-35.2" to table top frame/18.0"-37.2" to top of cushion <i>(heights nominal)</i>
Item No. TWG8248.BTM:	Width-48"; Length-78"; Ht. Range- 16.0"-35.2" to table top frame/18.0"-37.2" to top of cushion <i>(heights nominal)</i>
Item No. TWG8332.BTM:	Width-32"; Length-78"; Ht. Range- 16.0"-35.2" to table top frame/18.0"-37.2" to top of cushion <i>(heights nominal)</i>
Item No. TWG8336.BTM:	Width-36"; Length-78"; Ht. Range- 16.0"-35.2" to table top frame/18.0"-37.2" to top of cushion <i>(heights nominal)</i>
Item No. TWG8342.BTM:	Width-42"; Length-78"; Ht. Range- 16.0"-35.2" to table top frame/18.0"-37.2" to top of cushion <i>(heights nominal)</i>
Item No. TWG8348.BTM:	Width-48"; Length-78"; Ht. Range- 16.0"-35.2" to table top frame/18.0"-37.2" to top of cushion <i>(heights nominal)</i>

Lifting Weight Capacity: A maximum static uniform load of 750 lbs.

Upholstered Top: 2" polyfoam with vinyl cover standard; Vinyl Coated Nylon & Herculite, optional. Has rounded corners and uses the steel frame as a bumper guard, per se. Vinyl conforms to California Fire Code 117.

Casters: Four Tente Swivel Casters with total lock mechanism, 3" diameter wheels, are standard.

Frame: Heavy gauge steel.

Finish: Polyurethane Pearl Grey standard; Porcelain optional.

Switch: Handset for adjusting switch, low voltage-VDC/mA of 12/50. Power supply serves as main disconnect device.

Electrical: Input: 110 VAC; 6.5 A Max; 60 Hz.

UL[®] Class: This medical device has been tested to the following standards:
ANSI/AAMI ES60601-1:2005
CSA C22-2 No. 60601-1:2008
IEC 60601-1:2005

13.0 STARTUP CONDITIONS:

13.1 Observe the following values and instructions when starting this device:

- Startup Ambient Temperatures are: +10° C (+50° F) to +30° C (+86° F)
- **DO NOT** connect the power supply mains cord to any power source outlet when temperatures fall below the ambient startup temperatures.
- The power supply mains cord serves as the on/off switch or disconnect to the device. Connecting the power supply mains cord to a power source energizes the control unit which may malfunction when starting device outside of the startup ambient temperatures.

14.0 OPERATING CONDITIONS:

- 14.1 Observe the following values when selecting a operating location:
- Ambient Temperature: +10° C (+50° F) to +30° C (+86° F)
 - Atmospheric Humidity: 5% to 85%

15.0 STORAGE CONDITIONS:

- 15.1 Observe the following values when selecting a storage location:
- Ambient Temperature: +10° C (+50° F) to +40° C (+104° F)
 - Atmospheric Humidity: 5% to 85%

16.0 TRANSPORT CONDITIONS:

- 16.1 Observe the following values when transporting product:
- Ambient Temperature: -32° C (-25° F) to +50° C (+122° F)
 - Atmospheric Humidity: 5% to 85%

17.0 NOTICE:

17.1 Design changes may have occurred in the product since this user manual was published. The technical information found within this manual was correct at the time this user manual was approved for publication.

17.2 Tri W-G,[®] Inc. does not assume any risk or liability for attachments, or their effects on this device, if the attachments are not manufactured, sold by, and expressly approved by Tri W-G,[®] Inc.

17.3 When parts are required, use only those parts authorized by Tri W-G,[®] Inc.

17.4 If any information contained in this publication is not understood, the user should contact Tri W-G,[®] Inc. for assistance at 1-800-437-8011.

17.5 Do Not perform any electrical or general service on the table prior to disconnecting the power supply cord which serves as the on/off switch to the table.

18.0 TROUBLE SHOOTING

18.1 Table does not move up or down:

18.1.1 Check power cord connection to main power source.

18.1.2 Make sure main power source is receiving power.

18.1.3 Check handset, making sure it is plugged in.

18.1.4 Thermal protector may have activated, and you must allow the system to cool down. Duty Cycle is on/off intermittently 1 min/9 min.







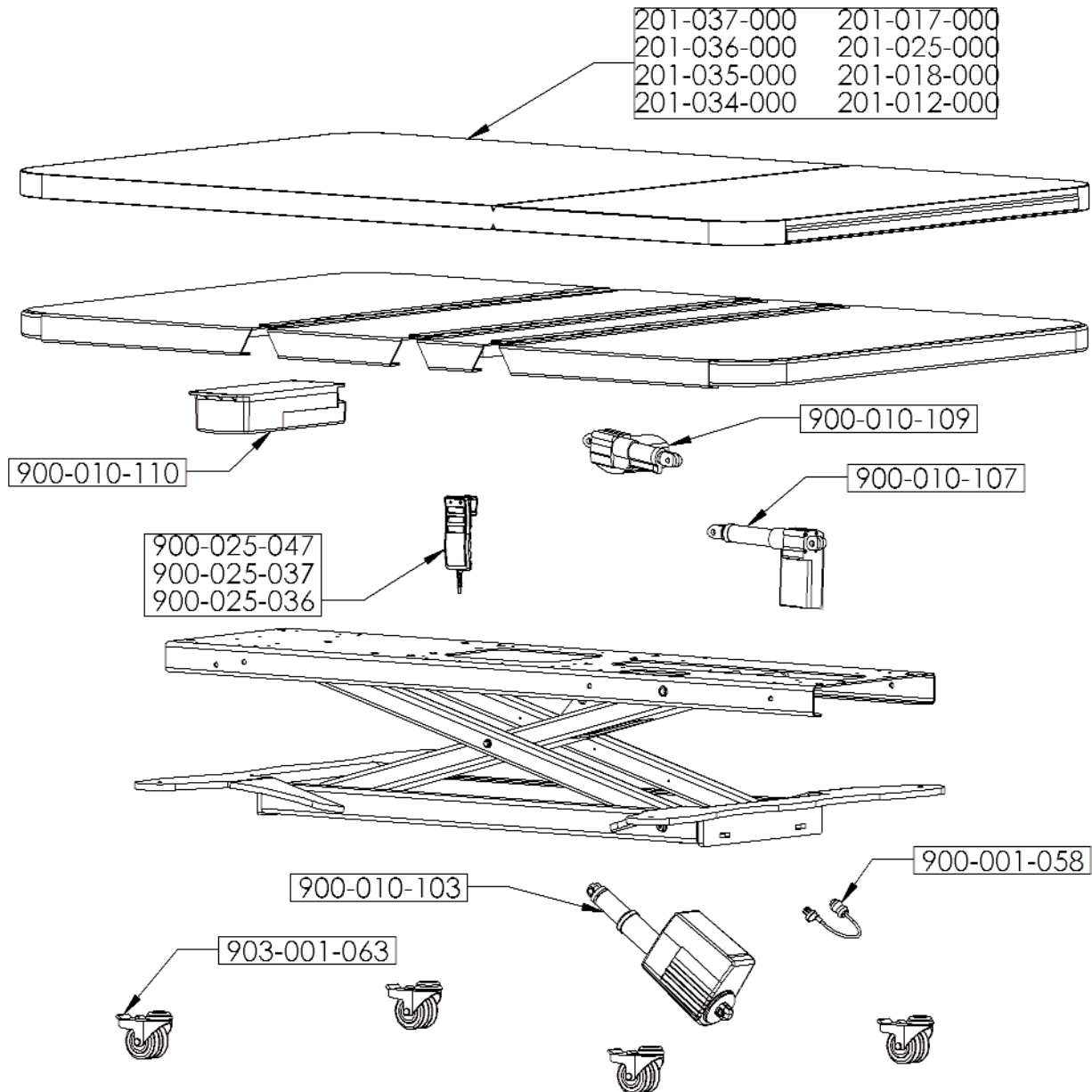

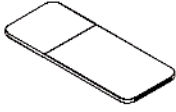
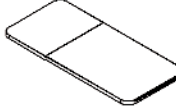
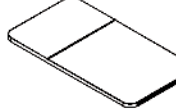

18.2 Tried everything and nothing works to resolve the dilemma--contact Tri W-G,[®] Inc. Customer Service by calling 1.800.437.8011.

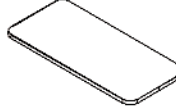
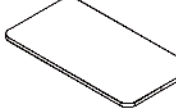
19.0 REPLACEMENT PARTS LOCATION SCHEMATIC

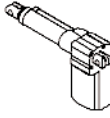
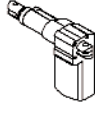
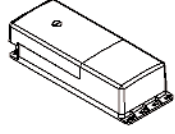
This replacement parts location schematic shows the service parts which may require service sometime in the future as the result of normal wear and tear. These parts can be ordered from the Tri W-G,[®] Inc. Service Dept by calling 1-800-437-8011. In the event any additional information is required, beyond what is shown below, please contact the Tri W-G,[®] Inc. Service Dept; which may include but not limited to--electrical diagrams, general service parts such as washers, bolts, connectors, etc.; and questions in general.

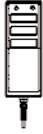

19.1 REPLACEMENT PARTS

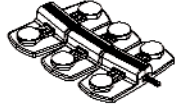
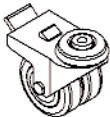
 <p>201-034-000 TWO AND THREE SECTION CUSHION 32"</p>	 <p>201-035-000 TWO AND THREE SECTION CUSHION 36"</p>	 <p>201-036-000 TWO AND THREE SECTION CUSHION 42"</p>	 <p>201-037-000 TWO AND THREE SECTION CUSHION 48"</p>
 <p>201-012-000 ONE SECTION CUSHION 32"</p>	 <p>201-018-000 ONE SECTION CUSHION 36"</p>	 <p>201-025-000 ONE SECTION CUSHION 42"</p>	 <p>201-017-000 ONE SECTION CUSHION 48"</p>
 <p>900-010-103 ACTUATOR RU25</p>	 <p>900-010-107 ACTUATOR BACKREST</p>	 <p>900-010-109 ACTUATOR, KNEE GATCH</p>	 <p>900-010-110 CONTROL UNIT</p>
 <p>900-025-036 HANDSET ONE ROW</p>	 <p>900-025-037 HANDSET TWO ROW</p>	 <p>900-025-047 HANDSET THREE ROW</p>	 <p>900-001-058 POWER CORD</p>
 <p>900-025-044 FOOTSWITCH, ONE CHANNEL (OPTION)</p>	 <p>900-025-049 FOOTSWITCH, TWO CHANNEL (OPTION)</p>	 <p>900-025-048 FOOTSWITCH, THREE CHANNEL (OPTION)</p>	 <p>903-001-063 CASTER</p>

20.0 DISPOSING OF THIS MEDICAL DEVICE

Deterioration in function, failure and/or the medical device has reached its life span, as a result of aging, wear, repeated use, or it has been determined to decommission it and/or dispose of it, must be done in a technically proper manner and in accordance with international, national, regional and/or local environmental regulatory requirements for disposing of medical devices. The owner of this medical device is responsible for its proper disposal.

LIMITED WARRANTY

This Product or Part is sold by Tri W-G,[®] Inc. under the limited warranties set forth in the following paragraphs. Such warranties are extended only with respect to the Purchase of the Product or Part as new merchandise directly from Tri W-G,[®] Inc. or a Tri W-G,[®] Inc. Authorized Dealer and are extended to the ultimate customer purchaser of the Tri W-G,[®] Inc. Product or Part.

Tri W-G,[®] Inc. warrants that each Product or Part sold hereunder shall be free of defects in material and workmanship for the Product warranty period identified as follows:

Ten Years: structural frame.

Two Years: operating system

365 Days: upholstery.

(Please note the aforementioned limited warranty is limited to original owner and not transferable.)

in the case of Products and twelve months in the case of Parts from the date of delivery from Tri W-G,[®] Inc. or an authorized Tri W-G,[®] Inc. Dealer, whichever is later. Should defects appear in any products subject to this limited warranty and Parts subject to this limited warranty sold hereunder within the respective limited warranty period, Tri W-G,[®] Inc. will repair or replace under the terms of this limited warranty any defective Part or Parts or provide new or remanufactured Parts when the defective Part or Parts are returned to Tri W-G,[®] Inc. facilities at Buyer's expense upon (20) days prior written notice to Tri W-G,[®] Inc. Buyer will be charged for any replacement Parts when shipped to Buyer by Tri W-G,[®] Inc. When the defective Parts are returned to Tri W-G,[®] Inc. pursuant to Tri W-G,[®] Inc. returned goods authorization, charges will be waived.

This limited warranty does not apply to any Products or Parts which have been damaged through misuse, negligence or accident (including shipping damage) on the part of Buyer or any third party. This limited warranty does not apply to any Product in which Parts other than replacement Parts or Parts approved by Tri W-G,[®] Inc. have been used if said Parts are or may be the cause of failure.

FOR ANY BREACH OF WARRANTY, EXPRESSED OR IMPLIED, THE LIABILITY OF TRI W-G,[®] INC. IS HEREBY EXPRESSLY LIMITED, AND SUBJECT TO THE TERMS HEREIN, TO THE REPAIR OR REPLACEMENT OF ANY PRODUCT OR PART WHICH SHALL APPEAR TO BE DEFECTIVE IN THE OPINION OF TRI W-G,[®] INC. THIS WARRANTY IS IN LIEU OF ALL OTHER WARRANTIES, EXPRESSED OR IMPLIED, INCLUDING WARRANTIES OF MERCHANTABILITY AND FITNESS FOR A PARTICULAR PURPOSE. IN NO EVENT SHALL TRI W-G,[®] INC. BE LIABLE FOR ANY SPECIAL, INCIDENTAL OR CONSEQUENTIAL DAMAGES. NO CLAIM FOR BREACH OF WARRANTY FOR PRODUCTS OR PARTS FURNISHED HEREUNDER SHALL BE ASSERTED AGAINST TRI W-G,[®] INC. MORE THAN TWENTY (20) DAYS AFTER THE EXPIRATION OF THE WARRANTY PERIOD.

DISCLAIMER

Every effort has been made to use accurate photography, drawings, product specifications and descriptions at the time of printing. However, because of continuous progressive product improvements, all specifications and descriptions are subject to change without prior notice.

Tri W-G® is a registered trademark of Tri W-G, Inc. UL® is a registered trademark of Underwriters Laboratories, Inc. All other company and product names are trademarks or registered trademarks of their respective owners.

(This page intended to not be used)

(This page intended to not be used)

(This page intended to not be used)

Manufactured and Distributed by:



Phone: 1-800-437-8011

Email: triwg@triwg.com

215 12th Avenue NE

PO Box 905

Valley City, ND 58072-0905